





Sicherheitshinweise

DE - In der Montageanleitung für den Schrank weist das Dreieck mit Ausrufezeichen auf die folgenden Sicherheitshinweise hin. Überschreiten Sie nicht die empfohlenen Belastungsgrenzen, um Verletzungen und Schäden am Schrank zu vermeiden. Es ist verboten, auf die Schubladen zu klettern oder sich dagegen zu lehnen. Halten Sie Kleinteile wie Schrauben, Schraubenabdeckungen usw. von Kindern fern, um Erstickungsgefahr zu vermeiden. Halten Sie sich strikt an den Montageplan. Die Montage muss von qualifiziertem Personal durchgeführt werden: Bei unsachgemäßer Ausführung kann das Produkt umkippen oder herunterfallen und Personen oder Sachen beschädigen. Da es verschiedene Arten von Wänden und Materialien gibt, sind die Schrauben zur Befestigung des Produkts an der Wand nicht im Lieferumfang enthalten: Wenden Sie sich an einen Fachhändler, um das für Ihre Wand am besten geeignete Befestigungszubehör auszuwählen.



Avvisi di sicurezza

IT - Nelle istruzioni di montaggio del mobile, il triangolo con punto esclamativo segnala i seguenti avvisi di sicurezza. Non superare i limiti di carico suggeriti, per evitare danni a persone e cose ed il danneggiamento del mobile stesso. E' vietato salire o appoggiarsi sui cassetti. Tenere lontano dai bambini i pezzi di ferramenta come viti, copri viti etc. per evitare eventuale soffocamento. Seguire scrupolosamente lo schema di montaggio. Il montaggio deve essere effettuato da personale qualificato: se non viene effettuato correttamente il prodotto può ribaltarsi o cadere, danneggiando persone o cose. Poiché ci sono pareti di diversi tipi e materiali, le viti per il fissaggio alla parete non sono incluse: rivolgeti ad un rivenditore specializzato per scegliere gli accessori per il fissaggio più adeguati alla tua parete.



Safety instructions

EN - In the assembly instructions for the cabinet, the triangle with the exclamation mark indicates the following safety instructions. Do not exceed the suggested load limits to avoid personal injury and damage to the cabinet. It is forbidden to climb on or lean against the drawers. Keep hardware such as screws, screw covers, etc. away from children to avoid possible suffocation. Strictly follow the assembly diagram. Assembly must be carried out by qualified personnel: if it is not done correctly, the product may tip over or fall, damaging people or property. Since there are different types of walls and materials, the screws for fixing the product to the wall are not included: contact a specialised dealer to choose the most suitable fixing accessories for your wall.



Avis de sécurité

Dans les notices de montage de l'armoire, le triangle avec point d'exclamation indique les recommandations de sécurité suivantes. Ne dépassez pas les limites de charge suggérées afin d'éviter dommages aux personnes, aux biens et au meuble même. Il est interdit de grimper ou s'appuyer sur les tiroirs. Gardez les éléments de quincaillerie tels que les vis, les cache-vis, etc. hors de la portée des enfants pour éviter tout risque de suffocation. Suivez scrupuleusement le schéma de montage. Le montage doit être effectué par du personnel qualifié : s'il n'est pas effectué correctement, le produit peut basculer ou tomber et causer des dommages corporels ou matériels. Étant donné qu'ils existent des différents types de murs et de matériaux, les vis de fixation du produit au mur ne sont pas incluses : contactez un revendeur spécialisé pour choisir les accessoires de fixation les plus adaptés à votre mur.



Veiligheidsinformatie

NL - In de montage-instructies voor de kast geeft de driehoek met uitroepteken de volgende veiligheidswaarschuwingen aan. Overschrijd de voorgestelde belastingslimieten niet, om letsel aan personen en schade aan de kast zelf te voorkomen. Het is verboden op de laden te klimmen of ertegen te leunen. Houd hardware zoals schroeven, schroefdeksels enz. uit de buurt van kinderen om verstikking te voorkomen. Volg strikt het montageschema. De montage moet worden uitgevoerd door gekwalificeerd personeel: als deze niet correct wordt uitgevoerd, kan het product kantelen of vallen en personen of eigendommen beschadigen. Aangezien er verschillende soorten muren en materialen bestaan, worden de schroeven voor bevestiging aan de muur niet meegeleverd: neem contact op met een gespecialiseerde dealer om de meest geschikte bevestigingsaccessoires voor uw muur te kiezen.

DE ALLGEMEINE INFORMATIONEN Es ist ratsam, qualifiziertes Personal für die Montage der Möbel und die Herstellung der erforderlichen Sanitär- und Elektroanschlüsse hinzuzuziehen.

Obwohl die Materialien der Komponenten feuchtigkeitsbeständig und für den Einsatz in Badezimmern geeignet sind, ist ein direkter Kontakt mit Wasser über einen Kontakt mit Wasser über einen zu langen Zeitraum wird nicht empfohlen.

Der Hersteller lehnt jede Verantwortung für die Folgen einer falschen Installation ab.

Der Hersteller lehnt jede Verantwortung für eine andere Verwendung des Produkts als die, für die es konzipiert wurde, ab.

REINIGUNG UND BEHANDLUNG Tinnern darf nicht zur Reinigung von Möbeln, Aceton oder Lösungsmitteln im Allgemeinen verwendet werden. Verwenden Sie nur neutrale, nicht scheuernde Reinigungsmittel.

IT INFORMAZIONI GENERALI

È consigliabile rivolgersi a personale qualificato per il montaggio dei mobili e l'esecuzione dei necessari collegamenti idraulici ed elettrici.

Sebbene i materiali che li compongono siano resistenti all'umidità e adatti all'uso in bagno, è sconsigliato il contatto diretto con l'acqua per un periodo troppo lungo. contatto diretto con l'acqua per un periodo eccessivamente lungo è sconsigliato.

Il produttore declina ogni responsabilità per le conseguenze di un'installazione non corretta.

Il Produttore declina ogni responsabilità per un uso del prodotto diverso da quello per cui è stato progettato.

PULIZIA E TRATTAMENTO Per la pulizia dei mobili non si devono usare diluenti, acetone o solventi in genere. Utilizzare solo detersivi neutri e non abrasivi.

EN GENERAL INFORMATION

It is advisable to call in qualified personnel to assemble the furniture and make the necessary plumbing and electrical connections.

Al though the component materials are resistant to moisture and are suitable for use in bathrooms, direct contact with water for an excessively long period is not recommended.

The producer declines any responsibility for the consequences of incorrect installation. The Producer declines every responsibility of a different use of the product from the one to which it has been designed.

CLEANING AND TREATMENT Tinnern must not be used to clean furniture, acetone or solvents in general. Only use neutral, non-abrasive cleaning agents

FR INFORMATIONS GÉNÉRALES Il est conseillé de faire appel à du personnel qualifié pour le montage des meubles et les raccordements électriques et de plomberie nécessaires.

Bien que les matériaux composant le meuble soient résistants à l'humidité et conviennent à une utilisation dans les salles de bains, le contact direct avec l'eau pendant une période trop longue n'est pas recommandé.

trop long n'est pas recommandé.

Le producteur décline toute responsabilité pour les conséquences d'une installation incorrecte.

Le Producteur décline toute responsabilité d'une utilisation du produit différente de celle pour laquelle il a été conçu.

NETTOYAGE ET TRAITEMENT Il est interdit d'utiliser des diluants pour le nettoyage des meubles, de l'acétone ou des solvants en général. Utiliser uniquement des produits de nettoyage neutres et non abrasifs.

NL ALGEMENE INFORMATIE Het is raadzaam een beroep te doen op gekwalificeerd personeel om de meubelen te monteren en de nodige loodgieters- en elektrische aansluitingen aan te brengen.

Hoewel de materialen van de onderdelen bestand zijn tegen vocht en geschikt zijn voor gebruik in badkamers te lange tijd met water in aanraking komen, wordt afgeraden.

De producent wijst elke verantwoordelijkheid af voor de gevolgen van onjuiste installatie. De producent wijst elke verantwoordelijkheid af voor een ander gebruik van het product dan waarvoor het ontworpen is.

REINIGING EN BEHANDELING Tinnern mogen niet gebruikt worden voor het reinigen van meubels, aceton of oplosmiddelen in het algemeen. Gebruik



MATERIAL FÜR DIE MONTAGE - MATERIAL FOR ASSEMBLY - MATERIALE PER L'ASSEMBLAGGIO - MATÉRIEL POUR L'ASSEMBLAGE - MATERIAAL VOOR ASSEMBLAGE

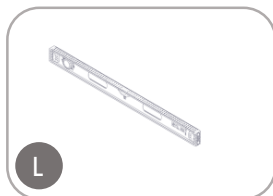

DE KAUFEN SIE EINEN FÜR DEN TYP GEEIGNETEN ANKER AUS WAND
IT ACQUISTARE L'ANCORAGGIO ADATTO AL TIPO DI MURO
EN BUY ANCHOR SUITABLE FOR THE TYPE OF WALL
FR ACHETER UNE ANCRE ADAPTÉE AU TYPE HORS MUR
NL KOOP EEN ANKER DAT GESCHIKT IS VOOR HET TYPE UIT DE MUUR

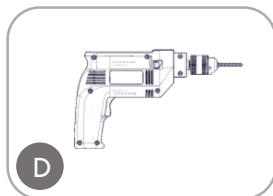
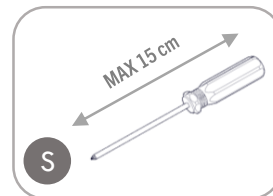
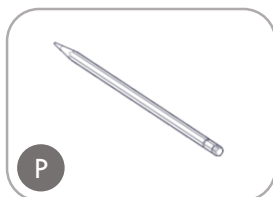
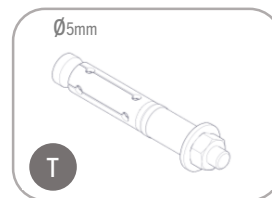
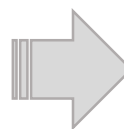



55 min.

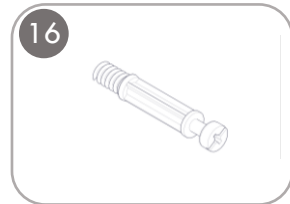
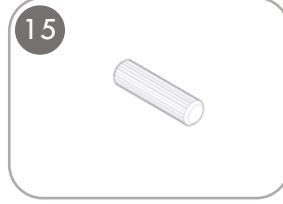
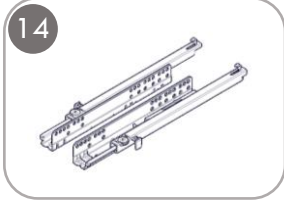
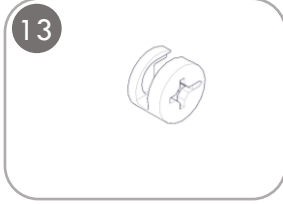
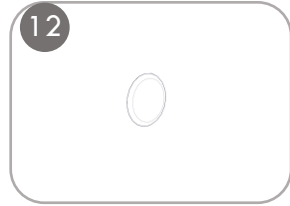
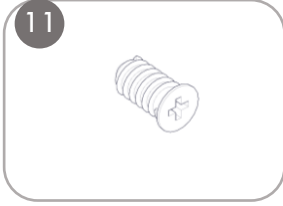
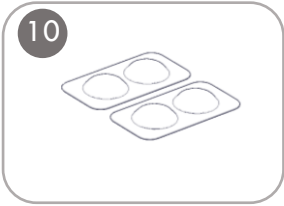
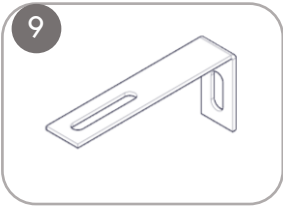
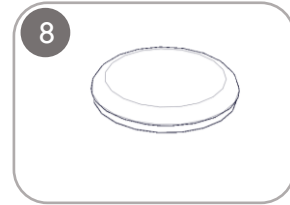
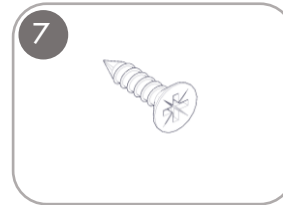
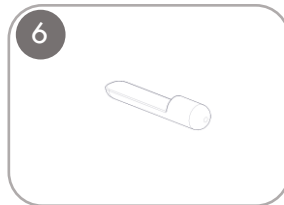
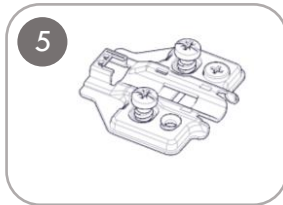
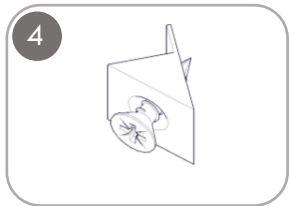
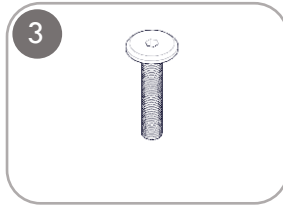
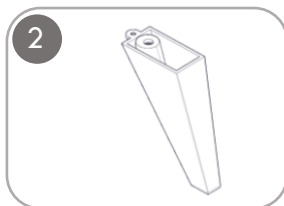
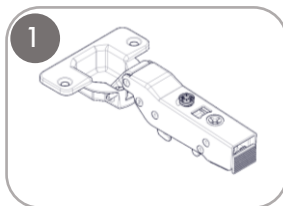
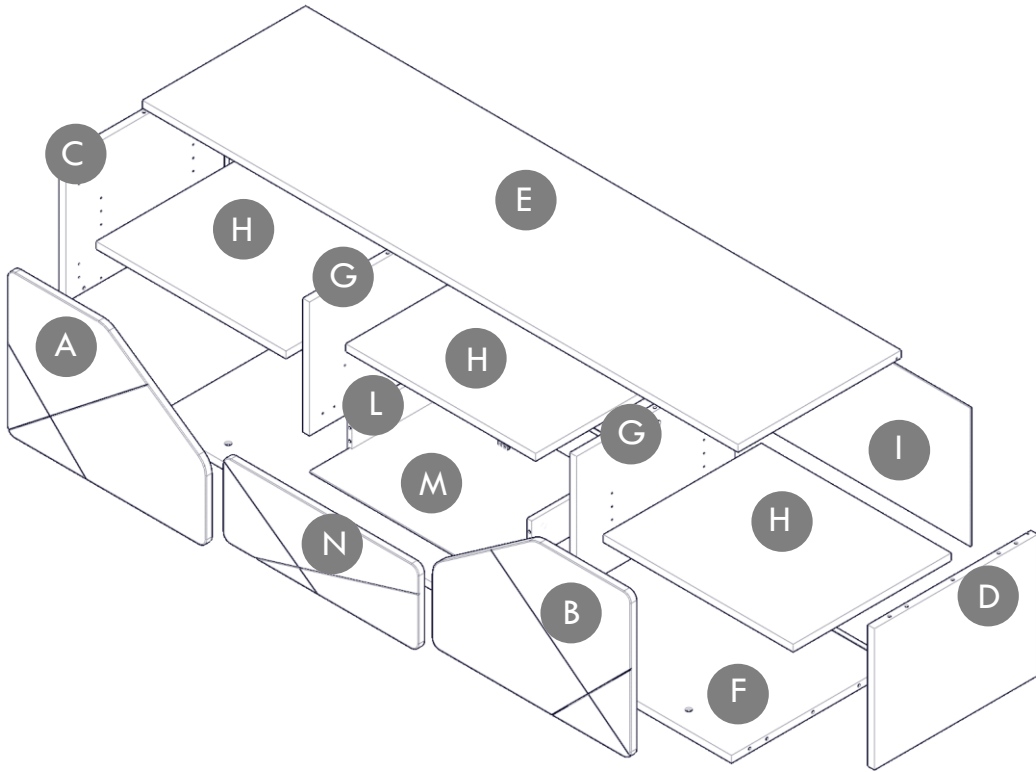

STEP 1

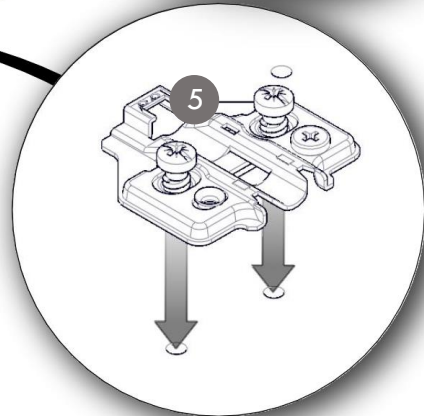
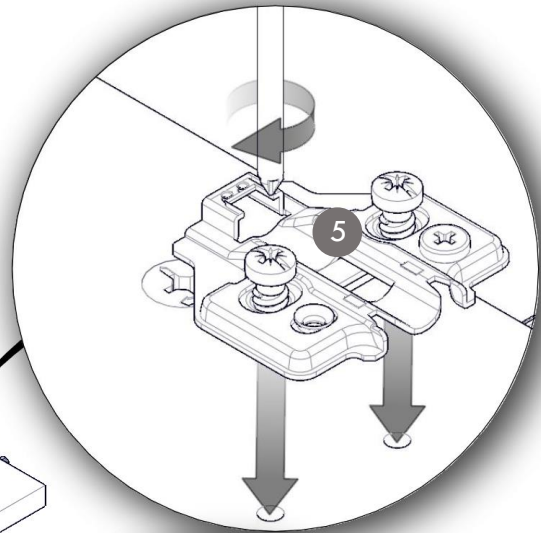
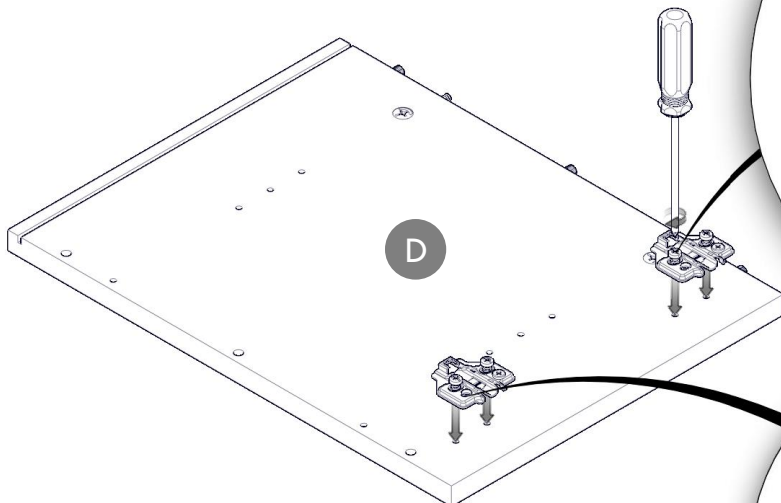
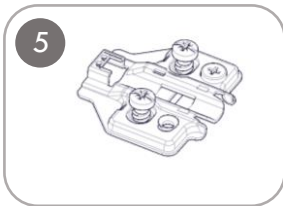
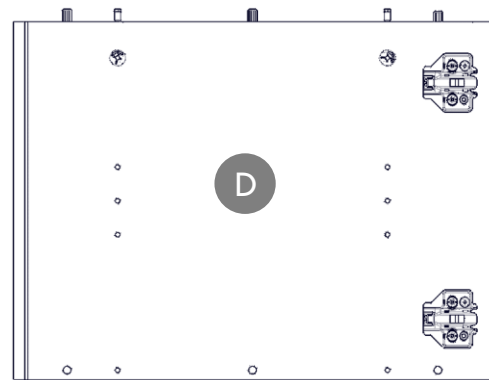
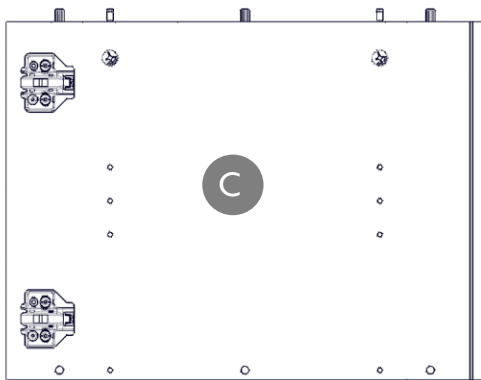

STEP 2



VELA
COLLECTION

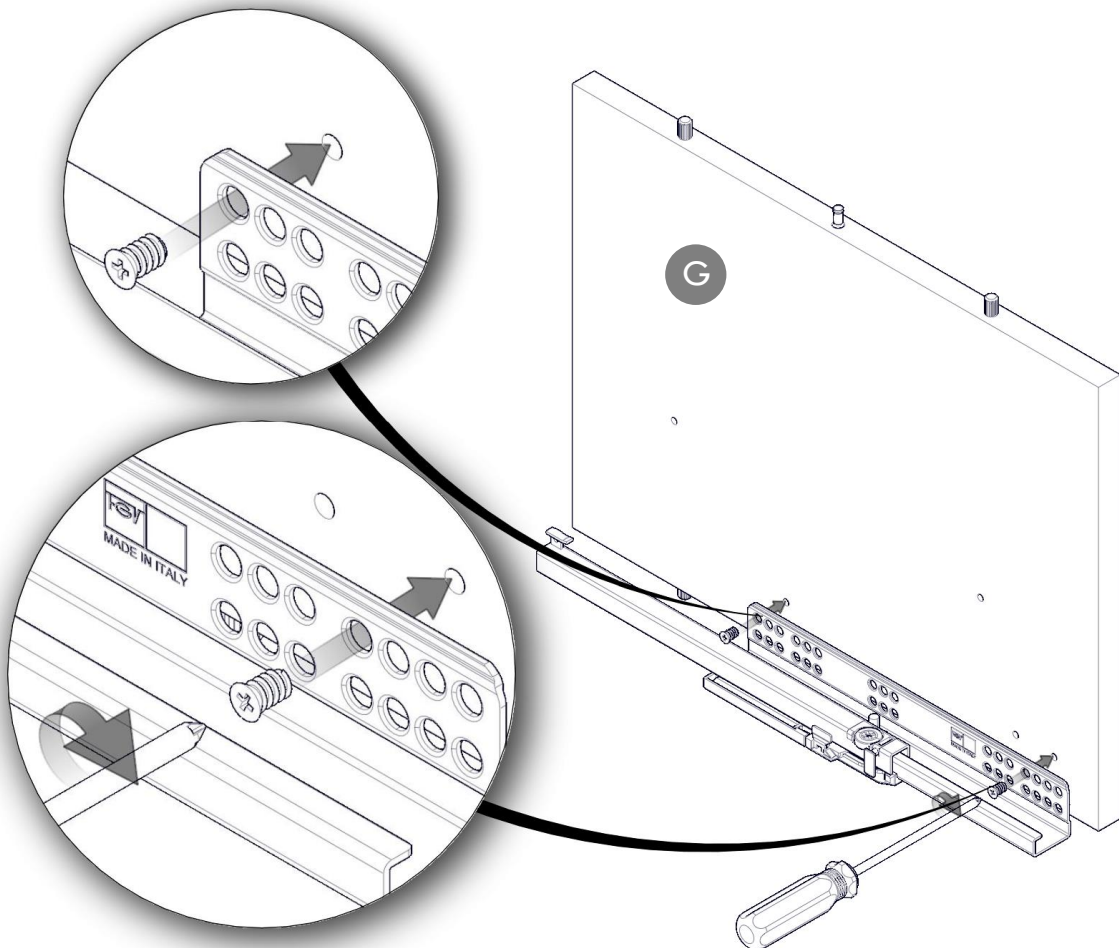
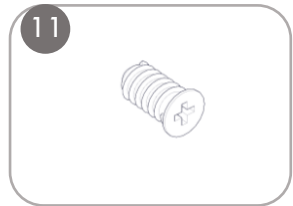
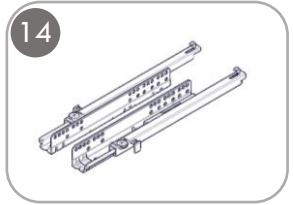

STEP 3



VELA
COLLECTION

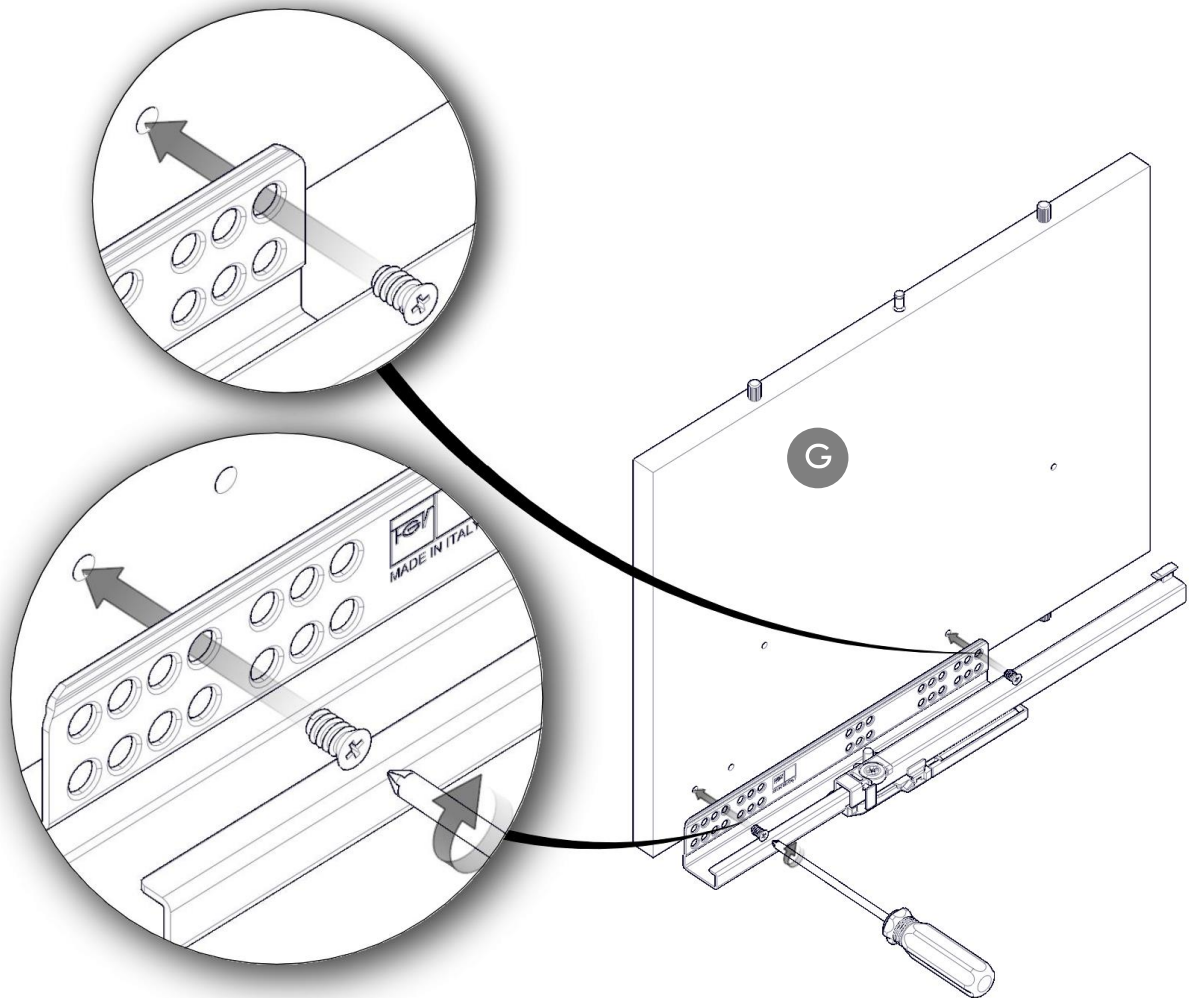
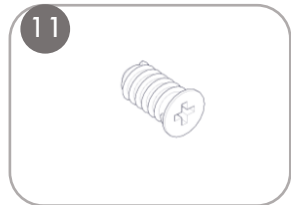
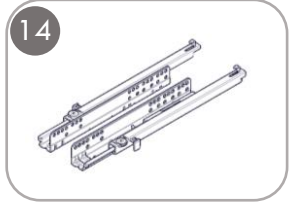

STEP 4



VELA
COLLECTION

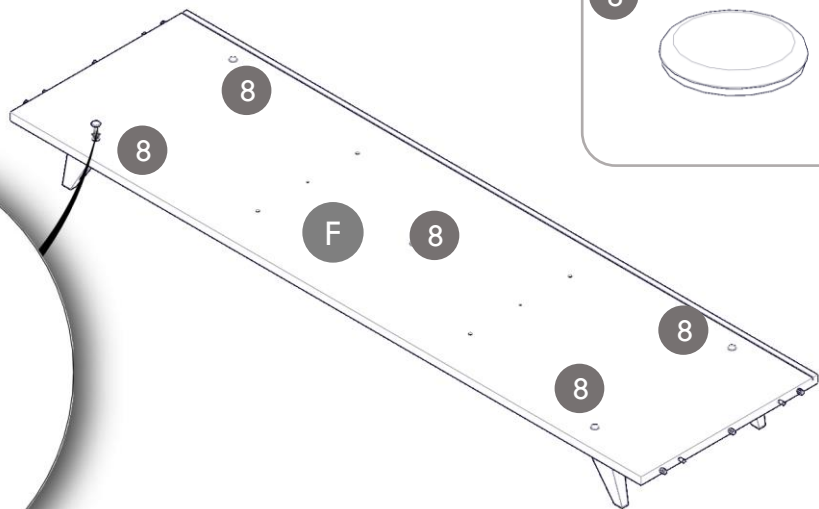
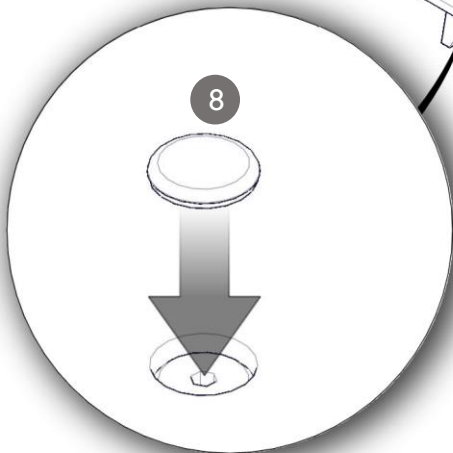
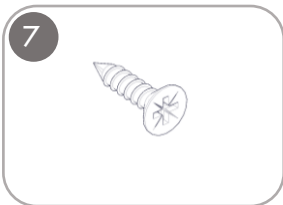
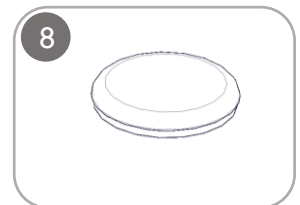
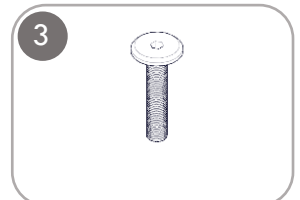
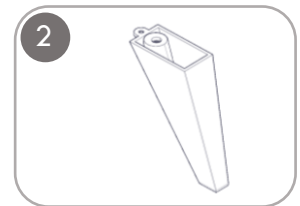
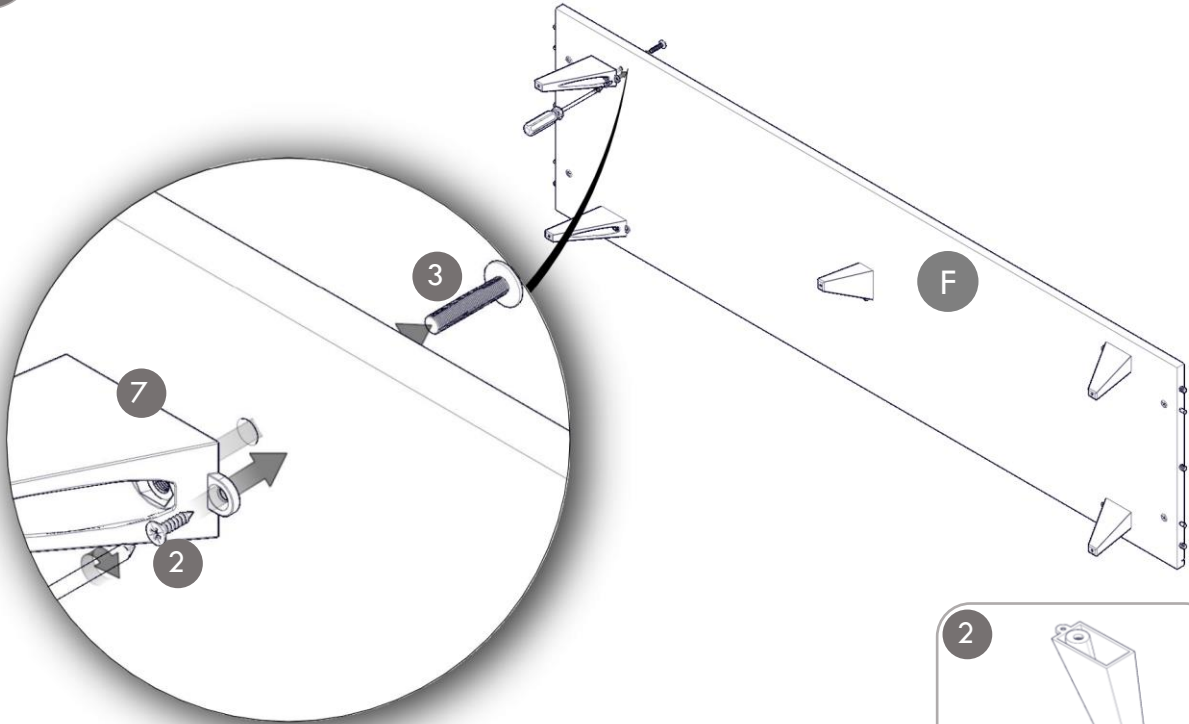

STEP 5



VELA
COLLECTION

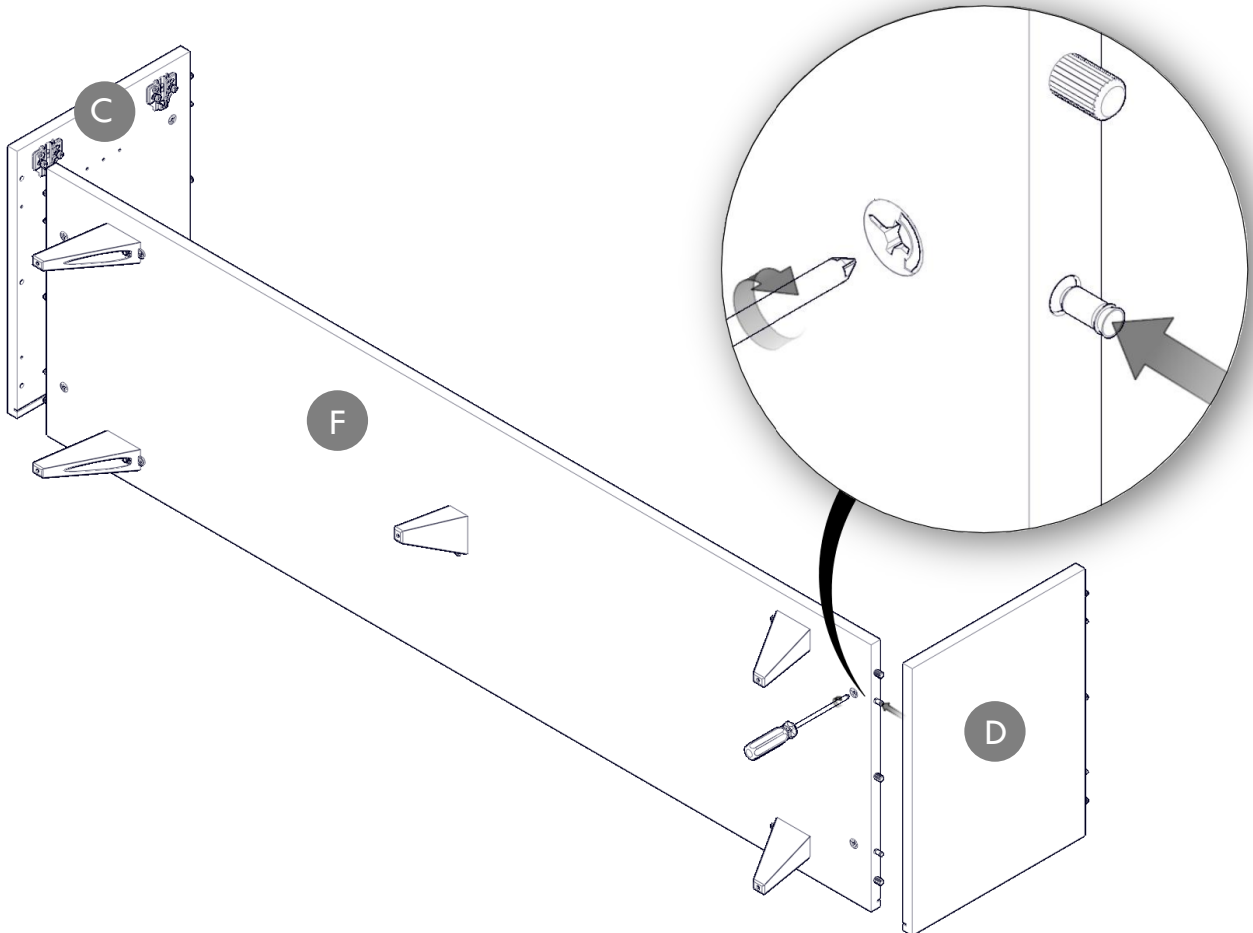
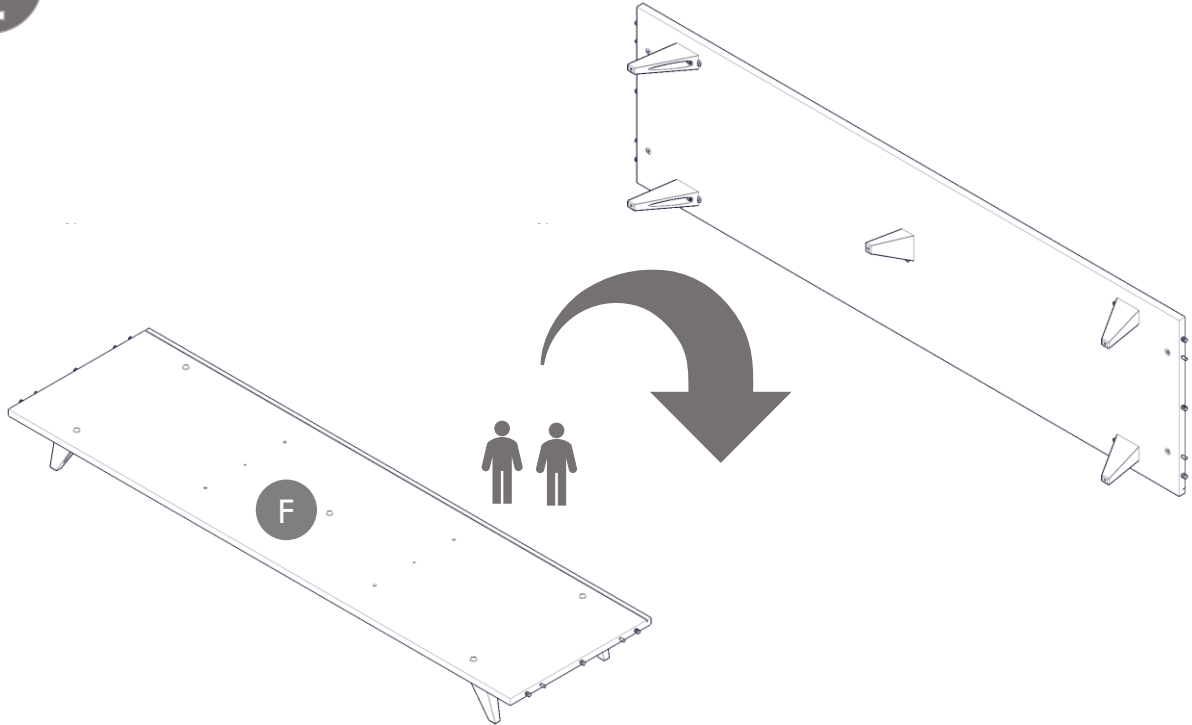

STEP 6



VELA
COLLECTION

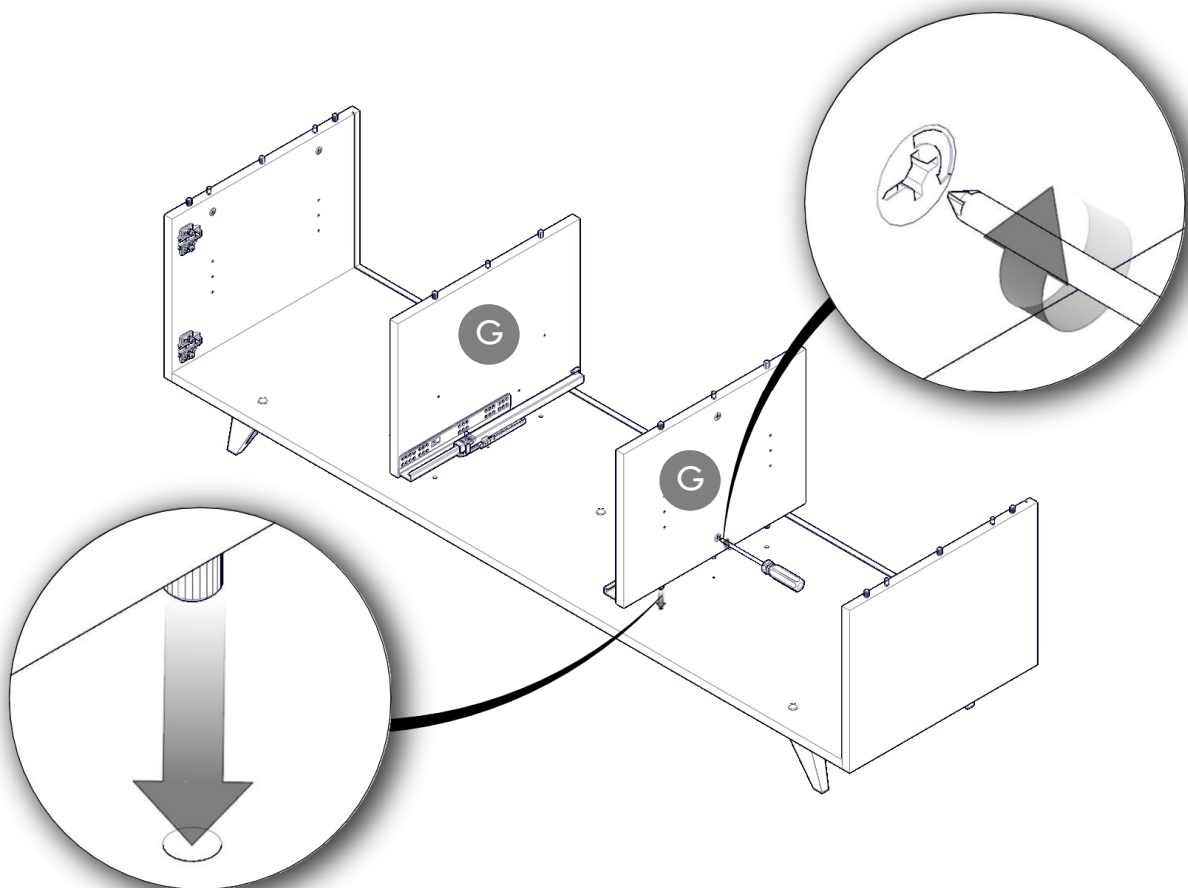
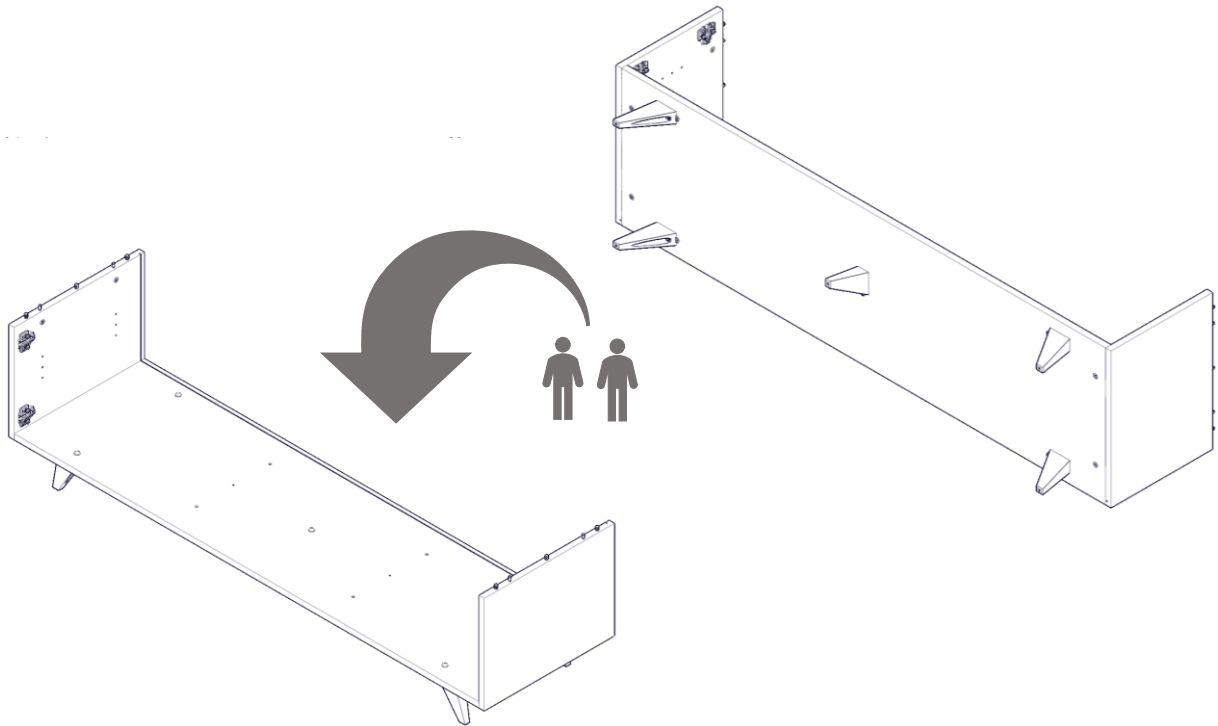

STEP 7



VELA
COLLECTION

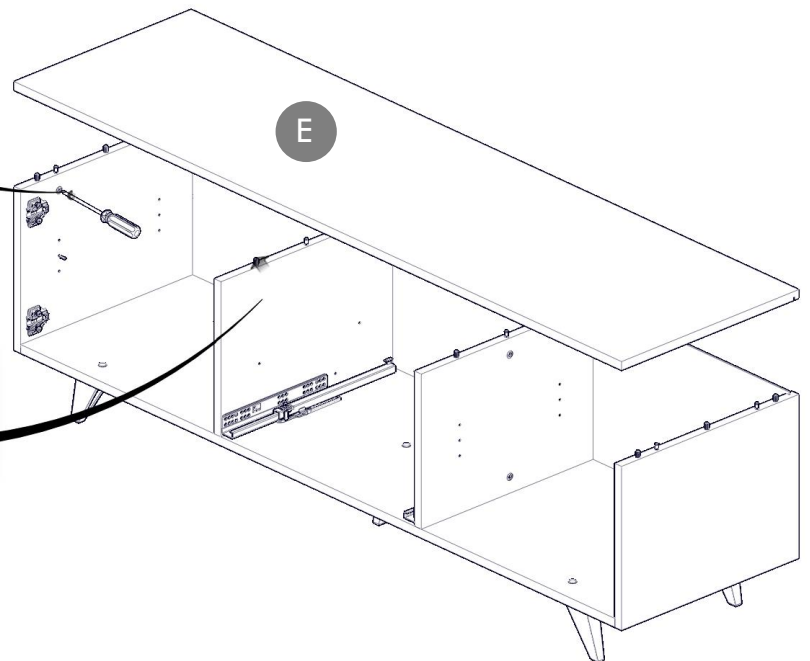
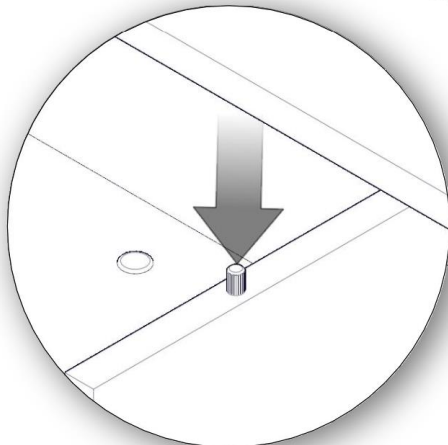
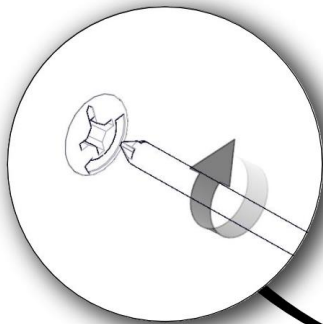
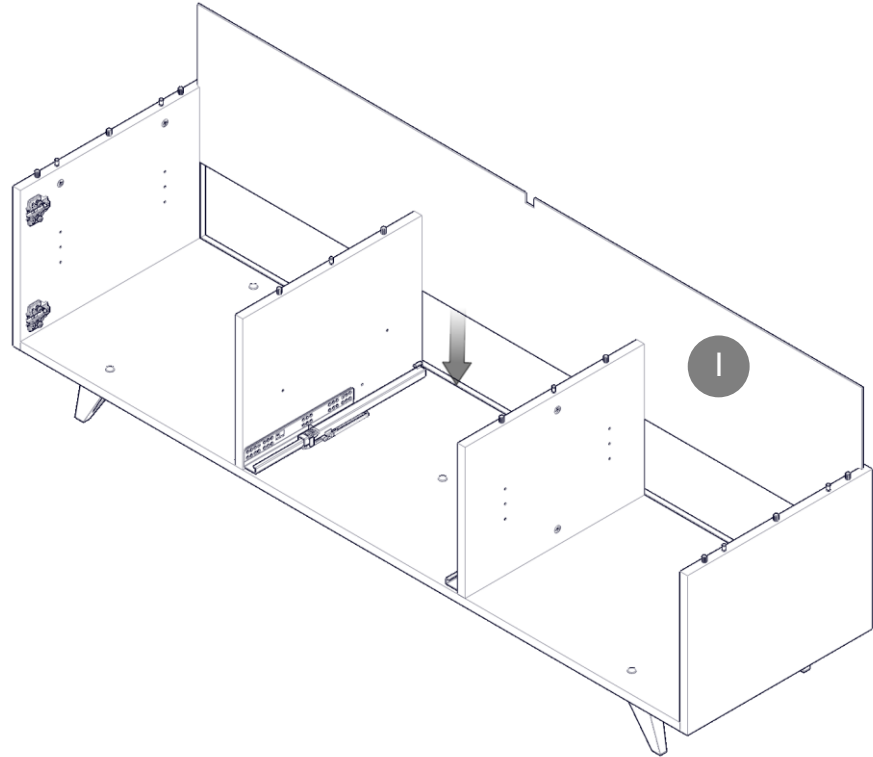

STEP 8



VELA
COLLECTION

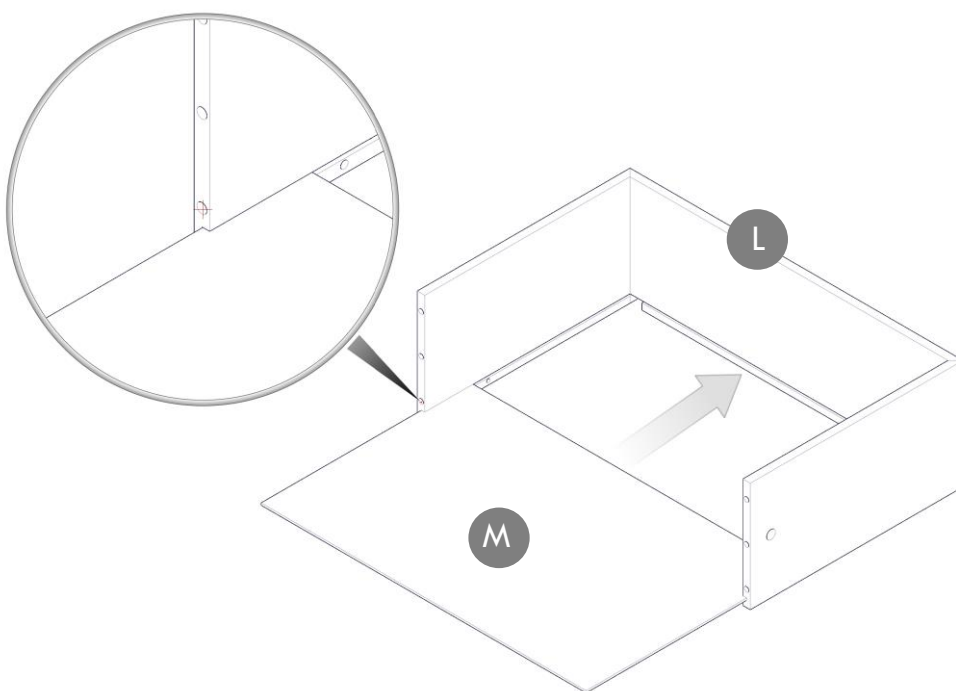
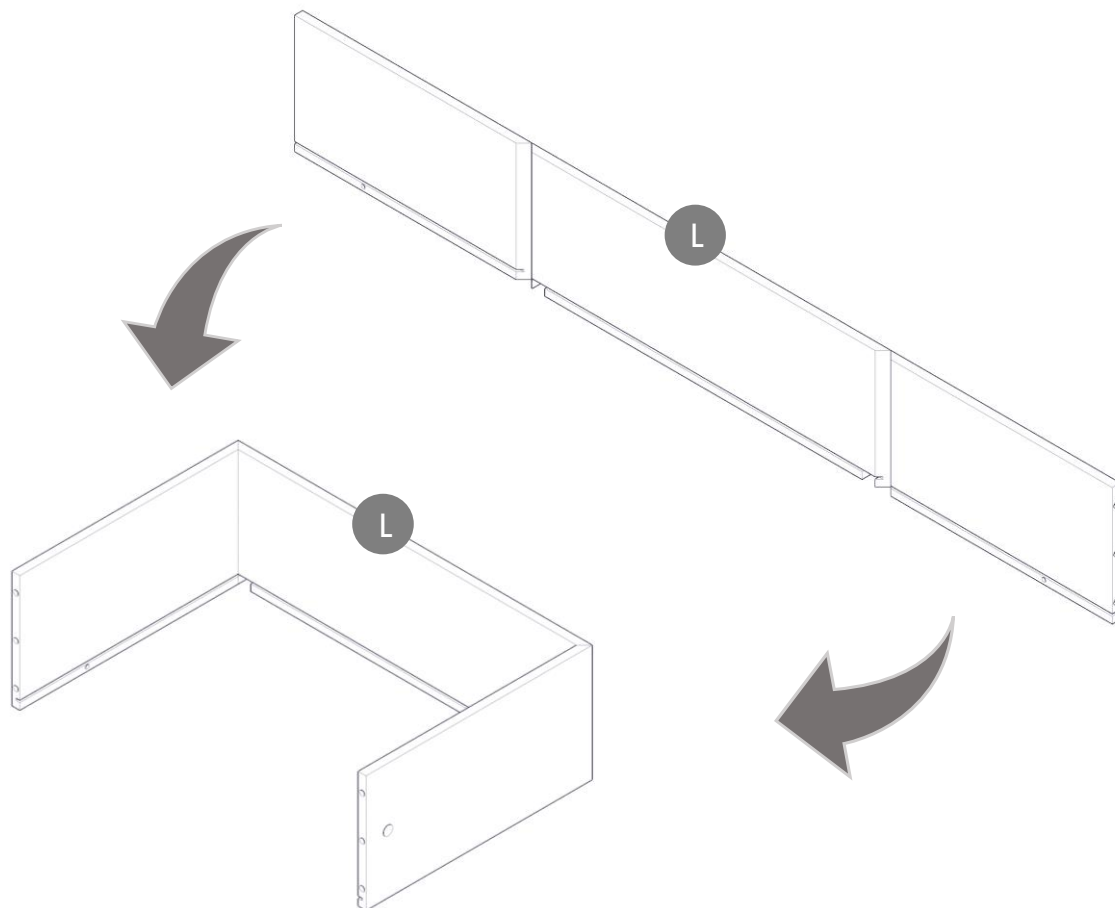

STEP 9

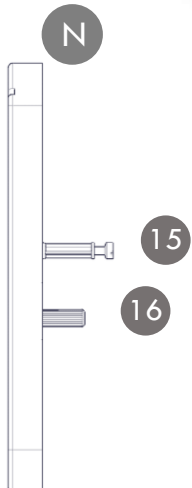
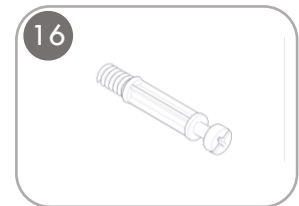
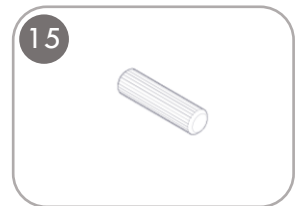
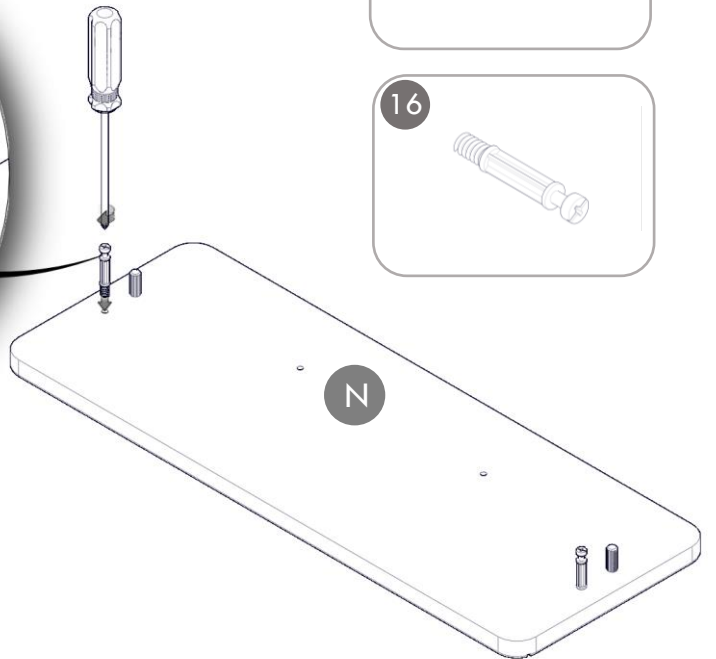
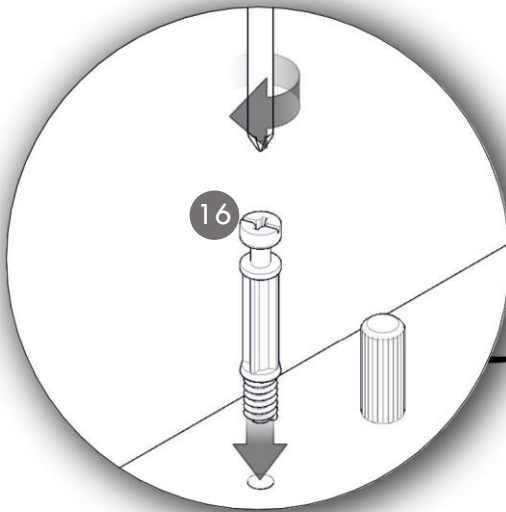
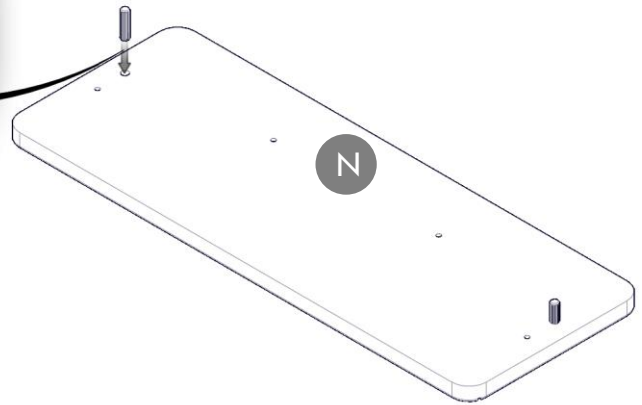
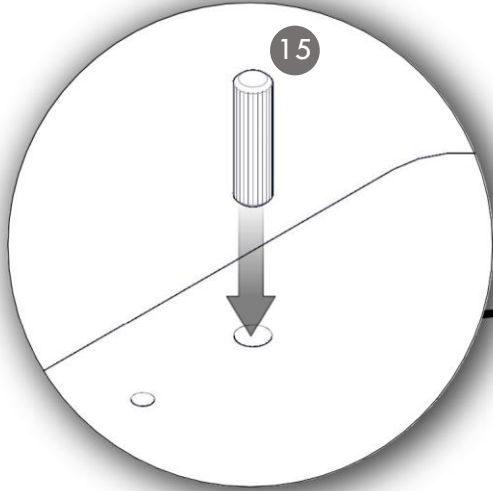

STEP 10



VELA
COLLECTION

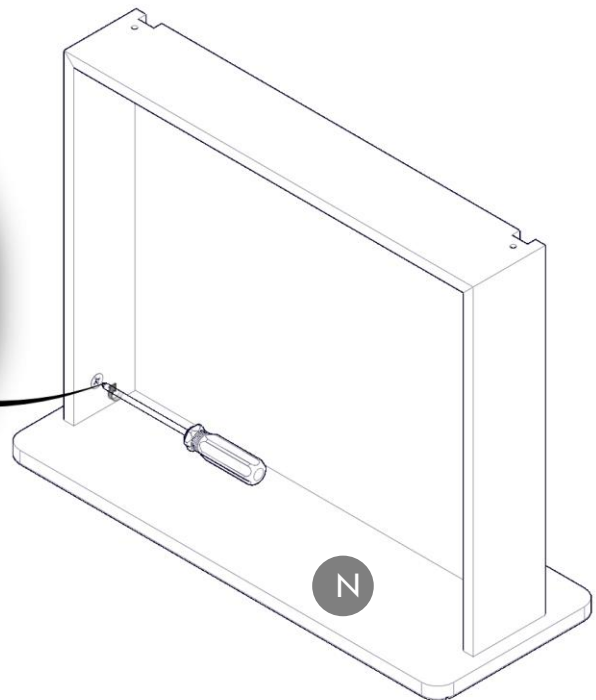
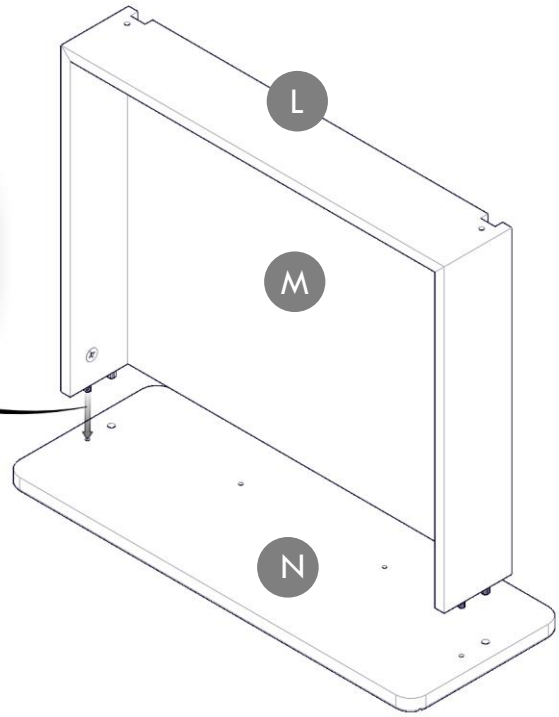
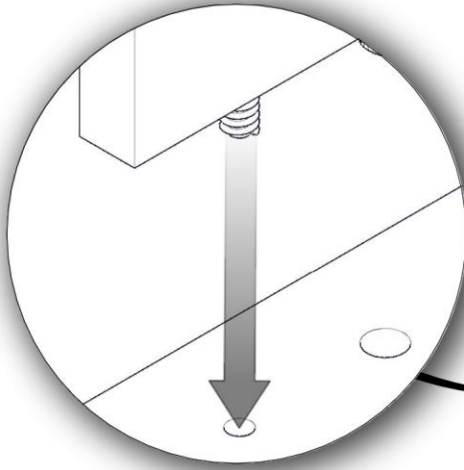

STEP 11



VELA
COLLECTION

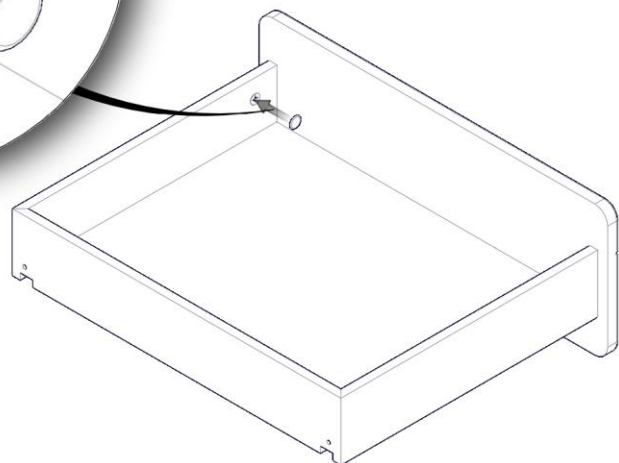
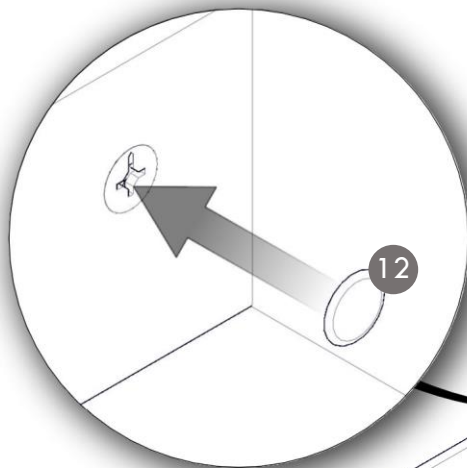
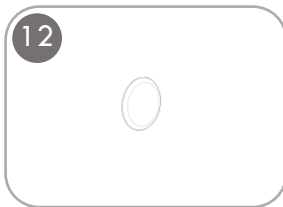
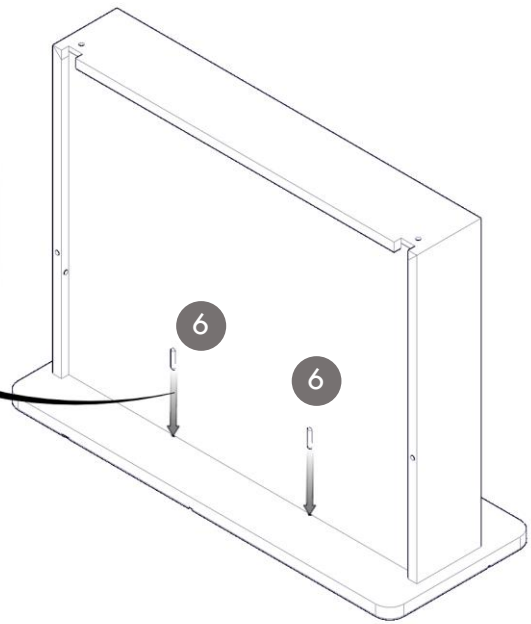
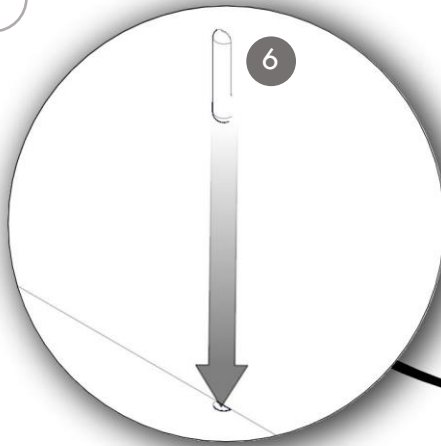
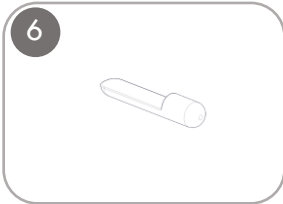

STEP 12



VELA
COLLECTION

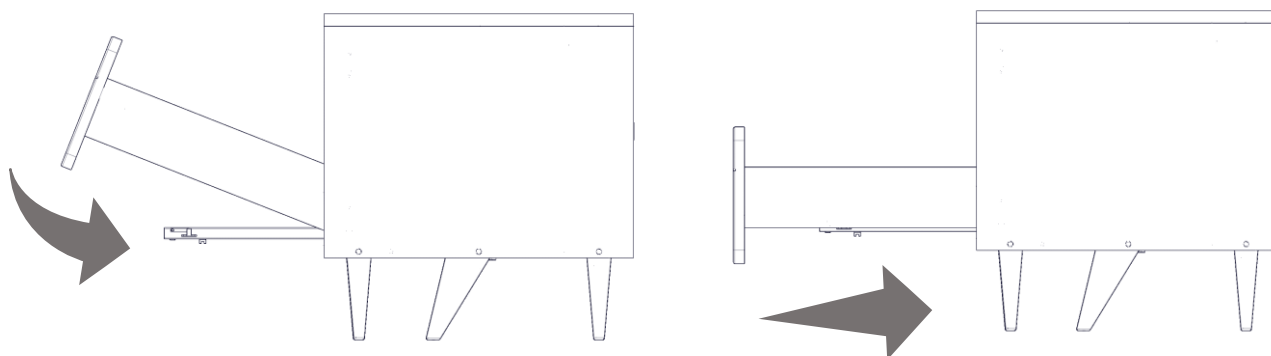
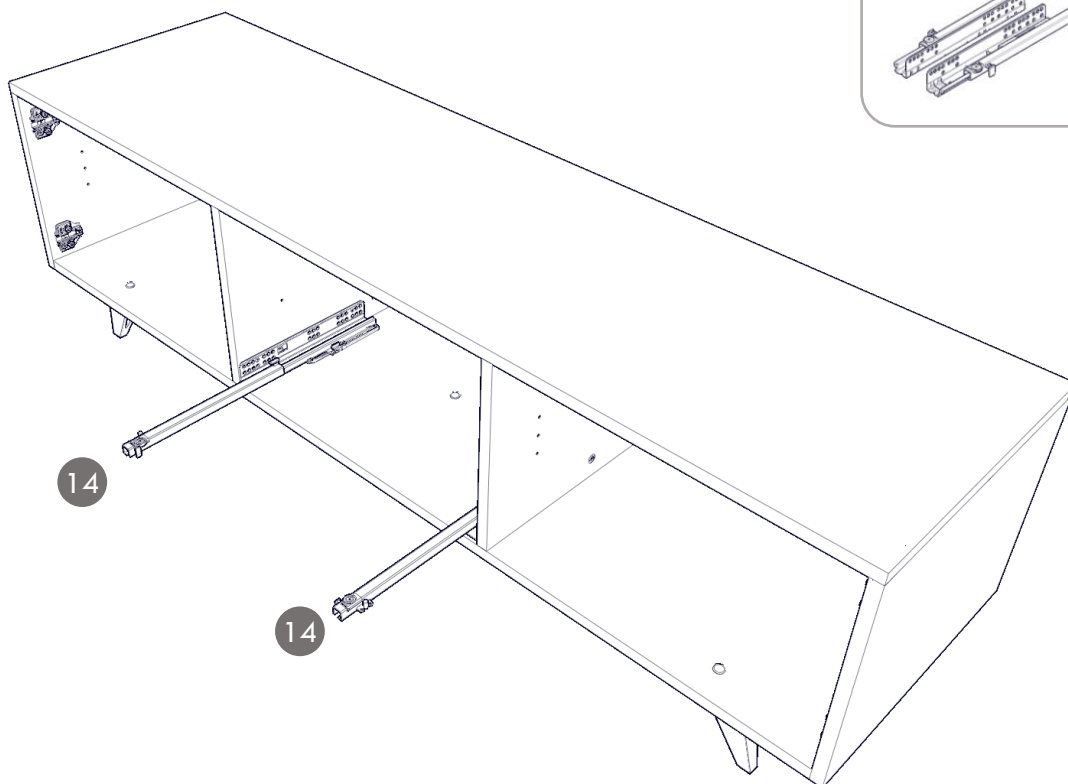
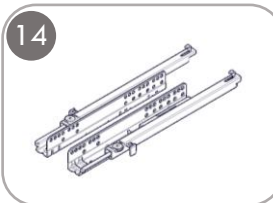

STEP 13



VELA
COLLECTION

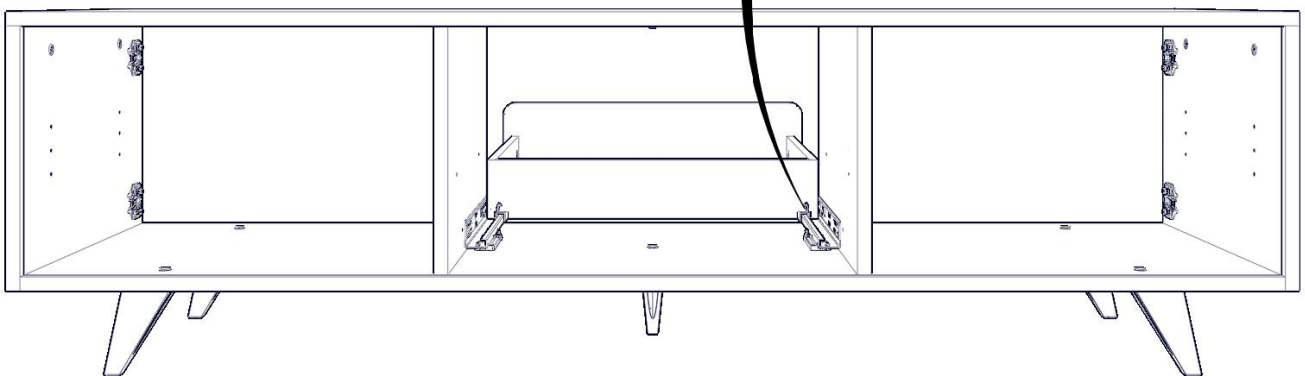
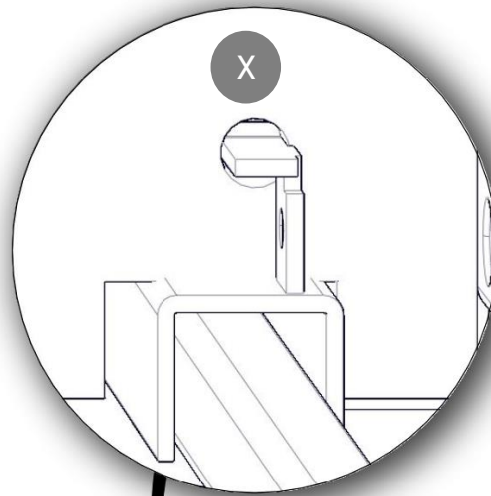
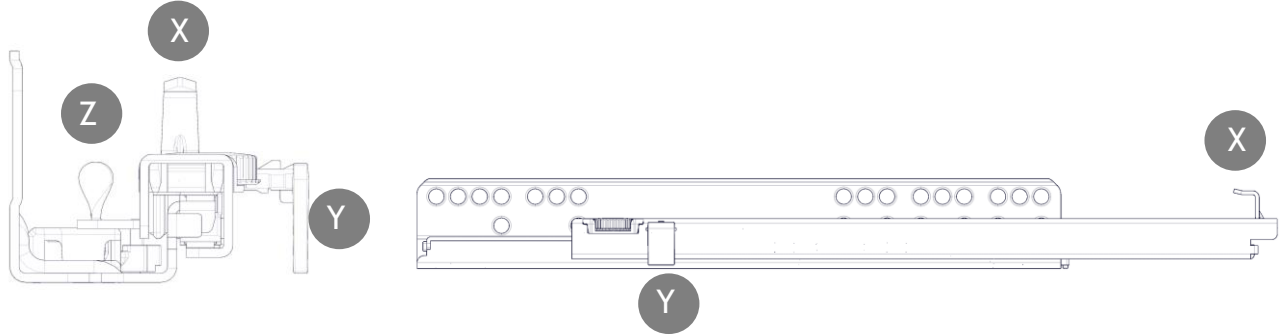

STEP 14



VELA
COLLECTION

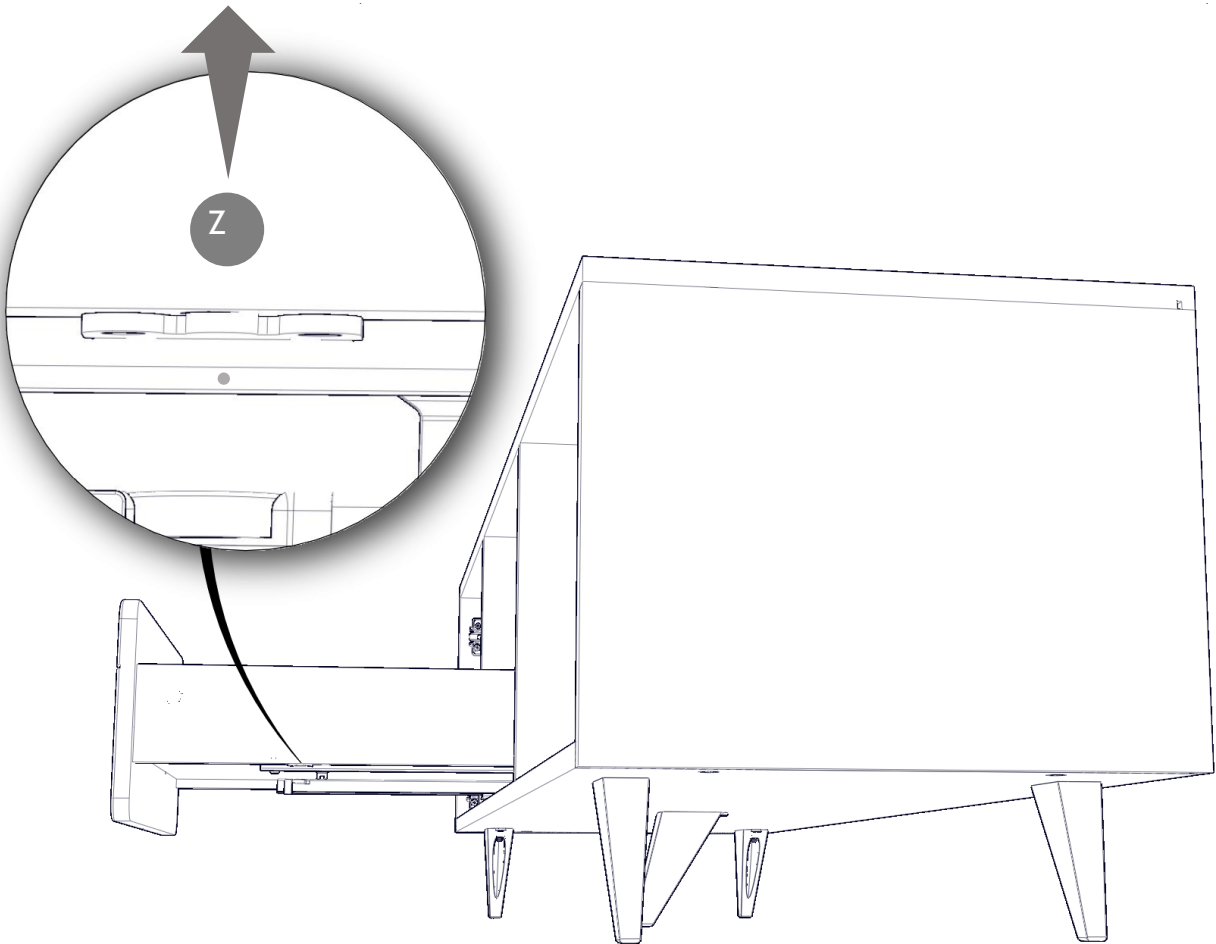
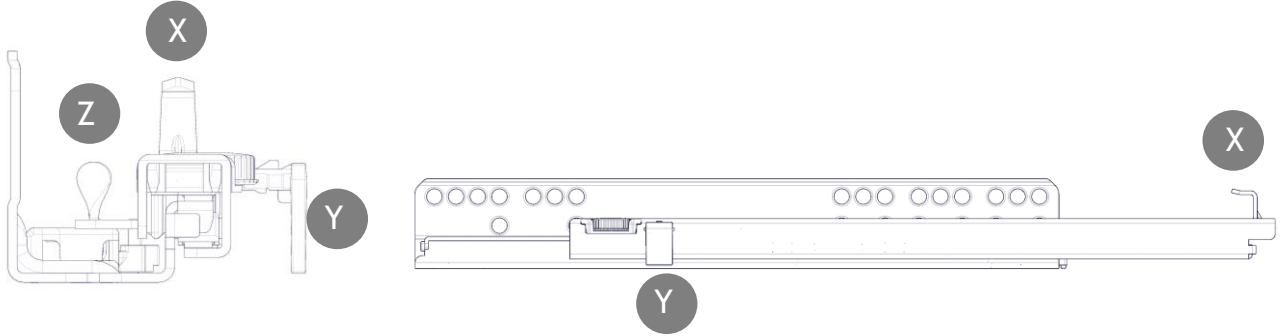

STEP 15



VELA
COLLECTION

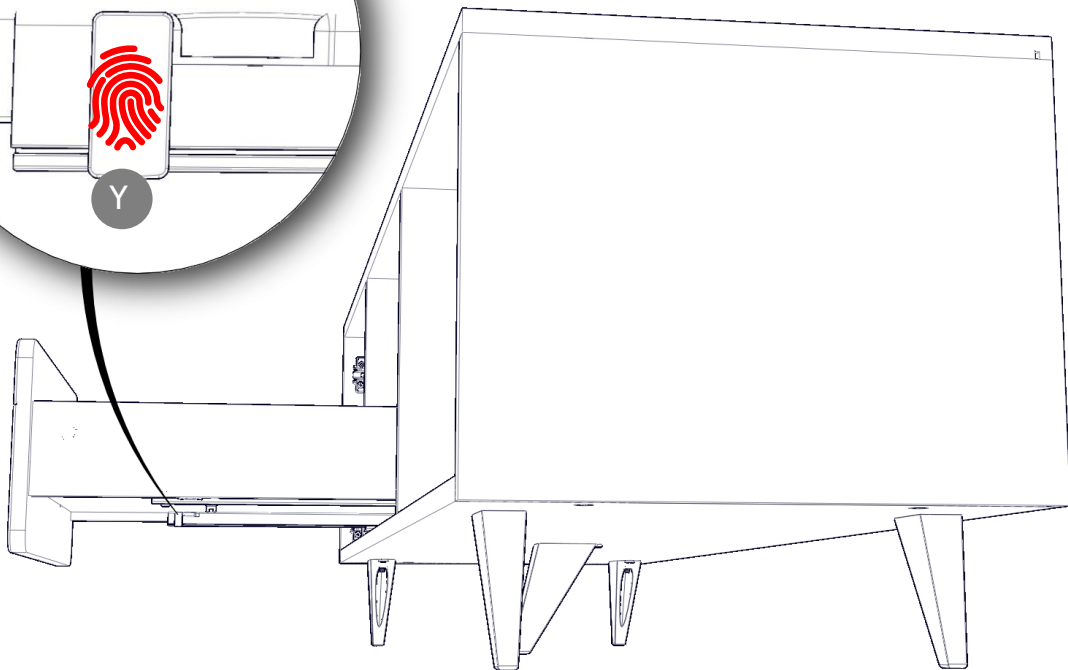
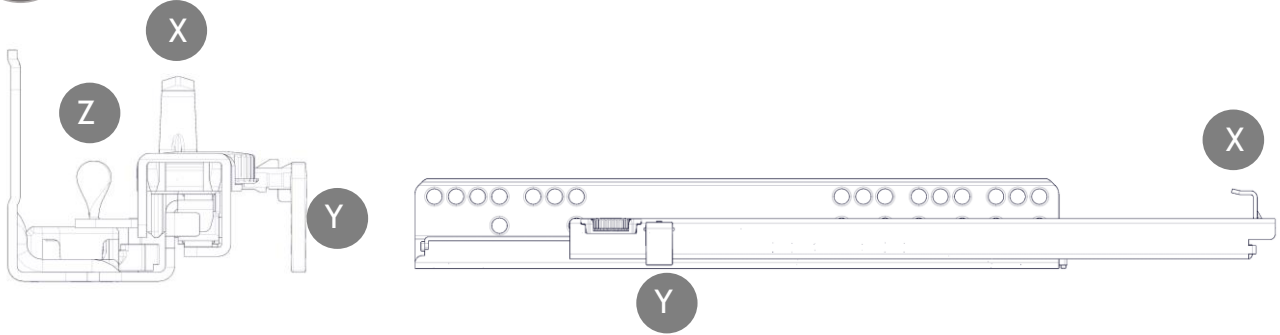

STEP 16



VELA
COLLECTION

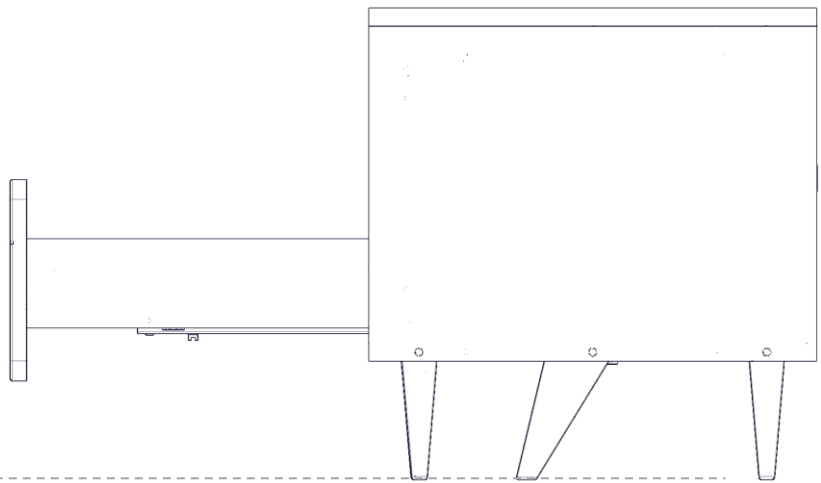
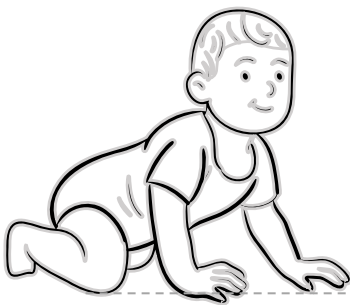

STEP 17



VELA
COLLECTION

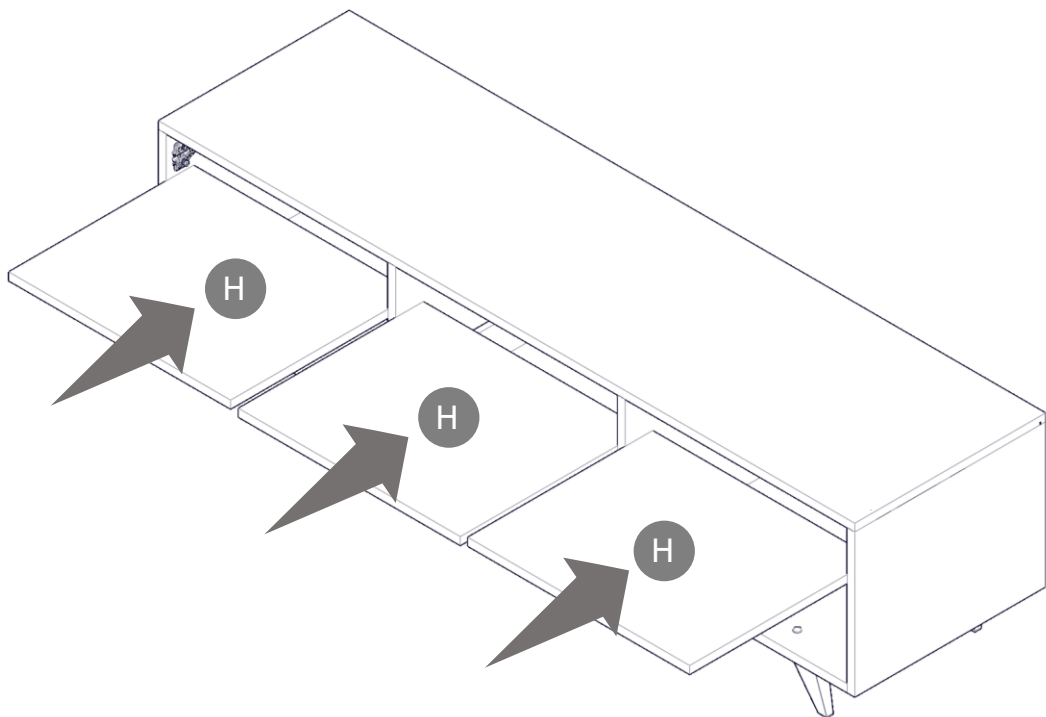
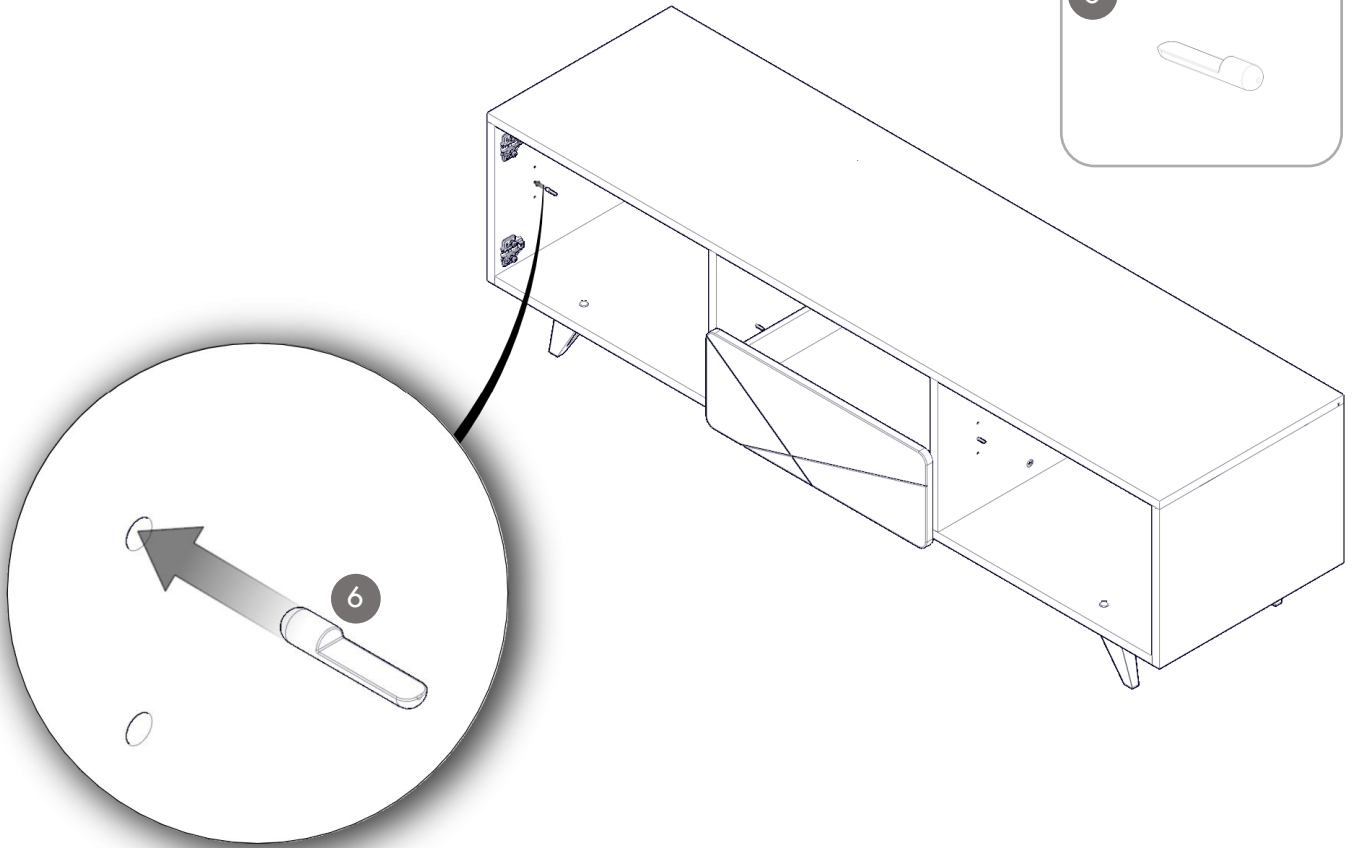
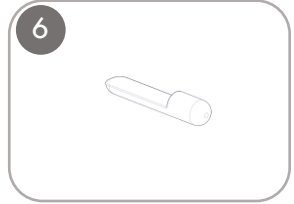

STEP 18



VELA
COLLECTION

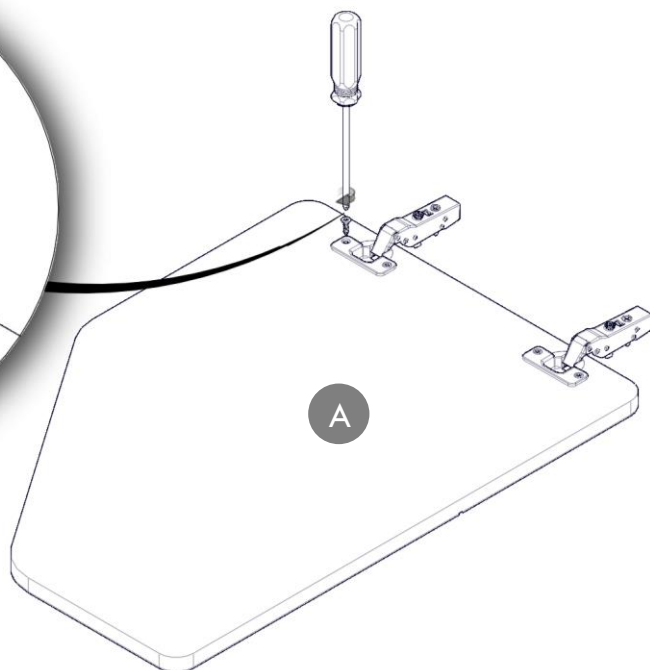
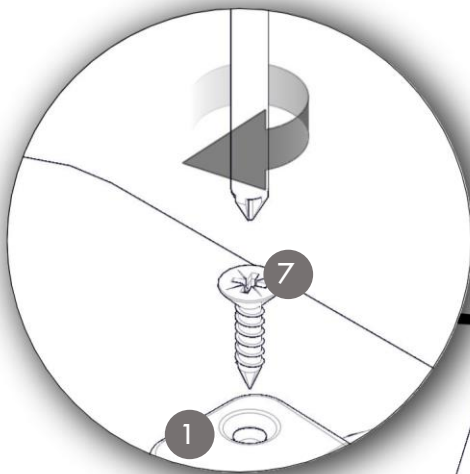
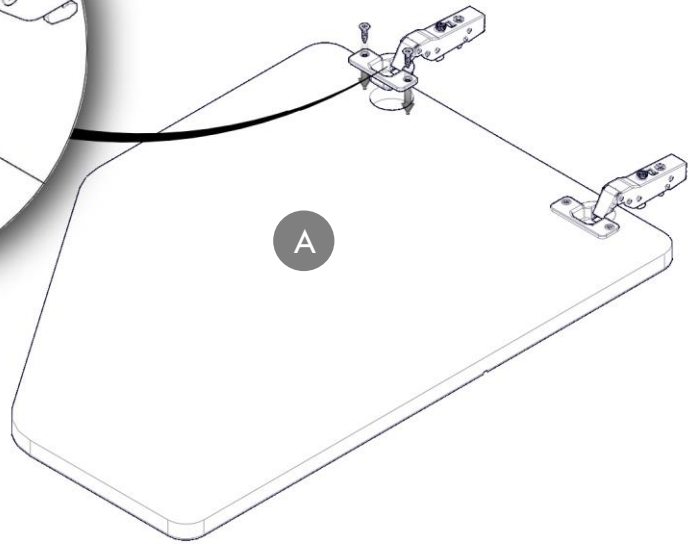
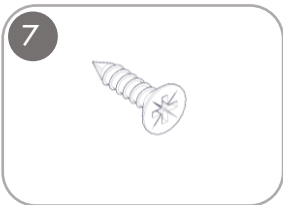
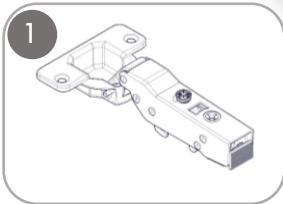
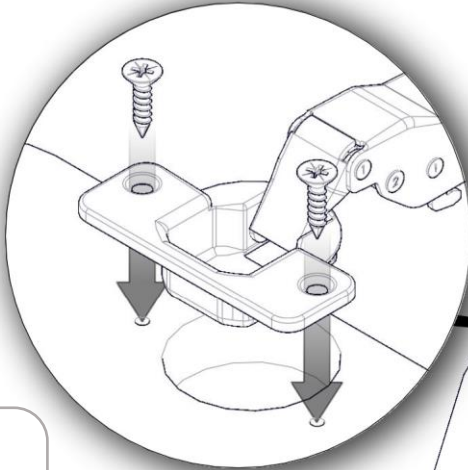

STEP 19



VELA
COLLECTION

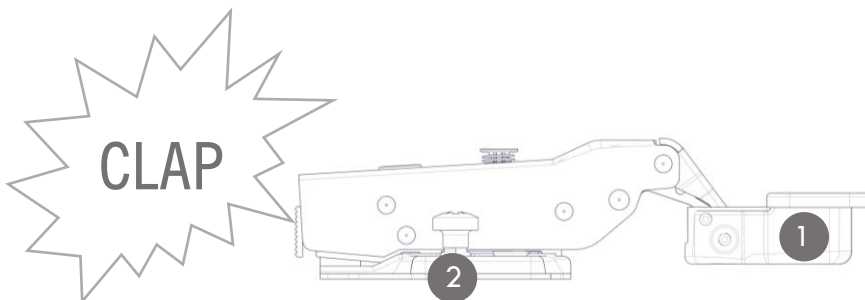
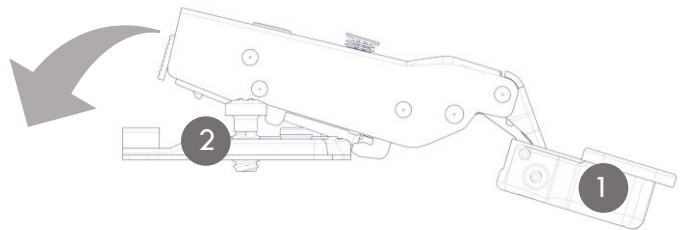
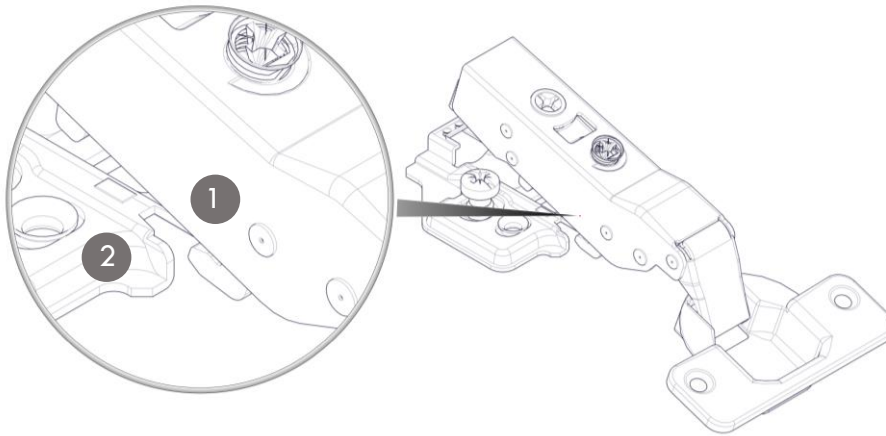
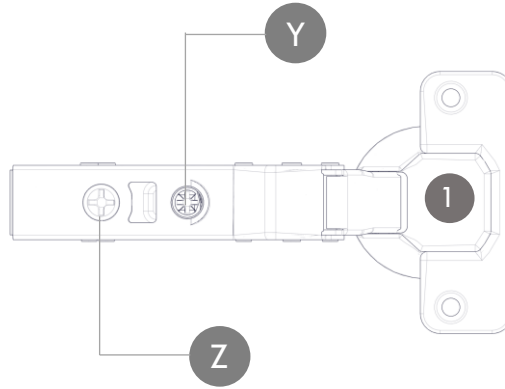
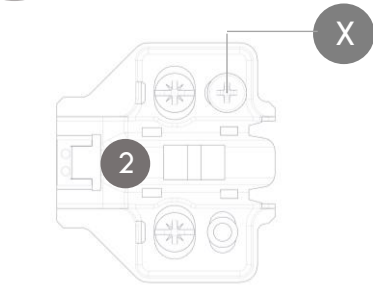

STEP 20



VELA
COLLECTION



Y

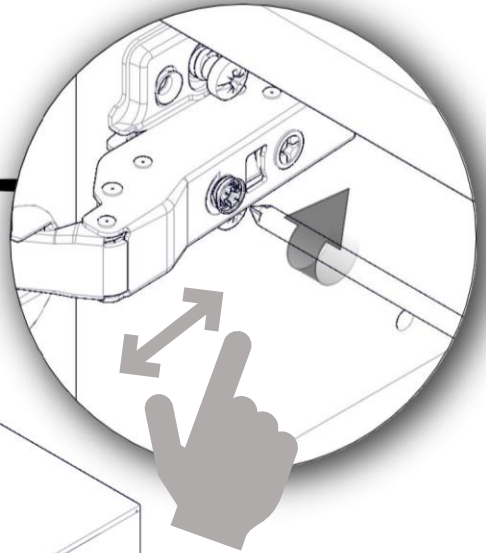
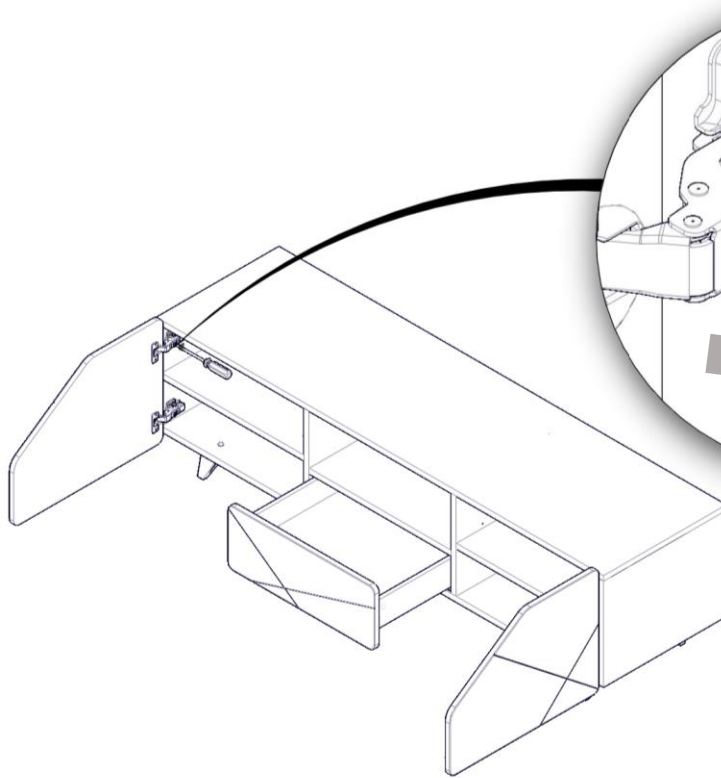
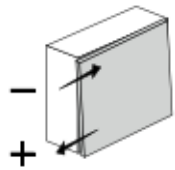
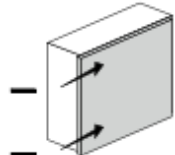
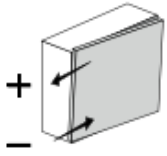
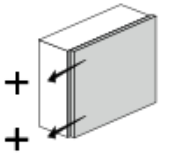

Z

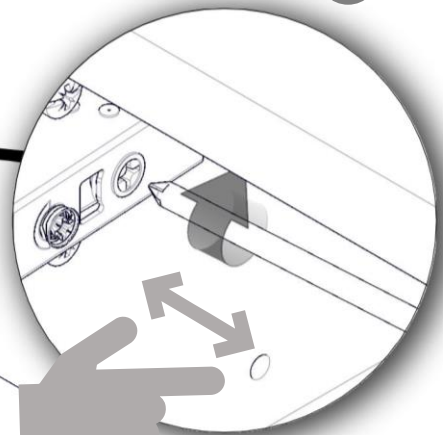
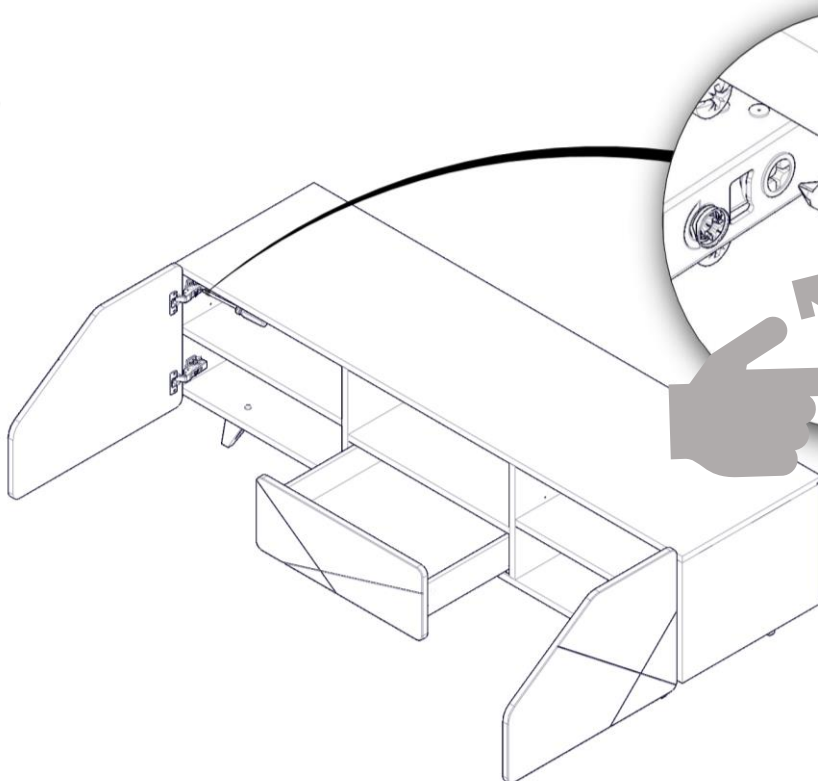
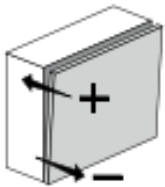

STEP 21



VELA
COLLECTION

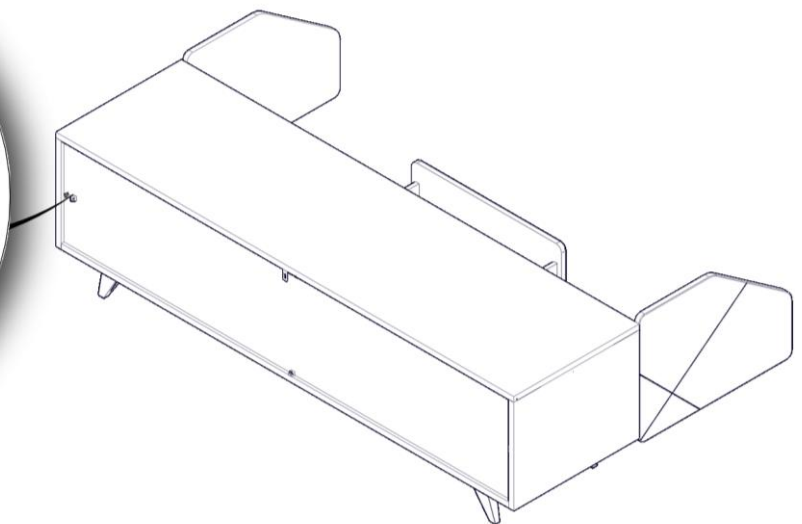
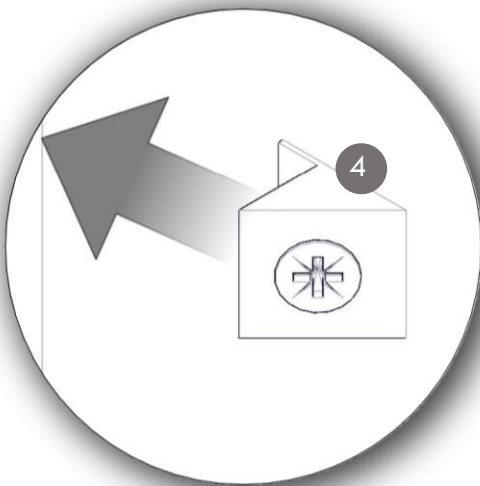
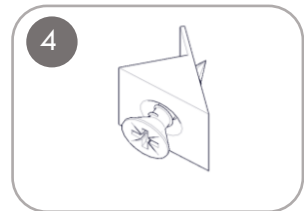
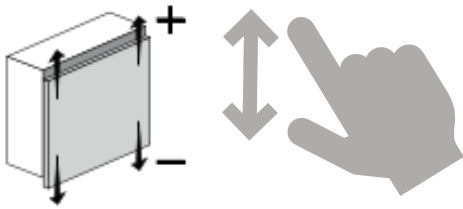
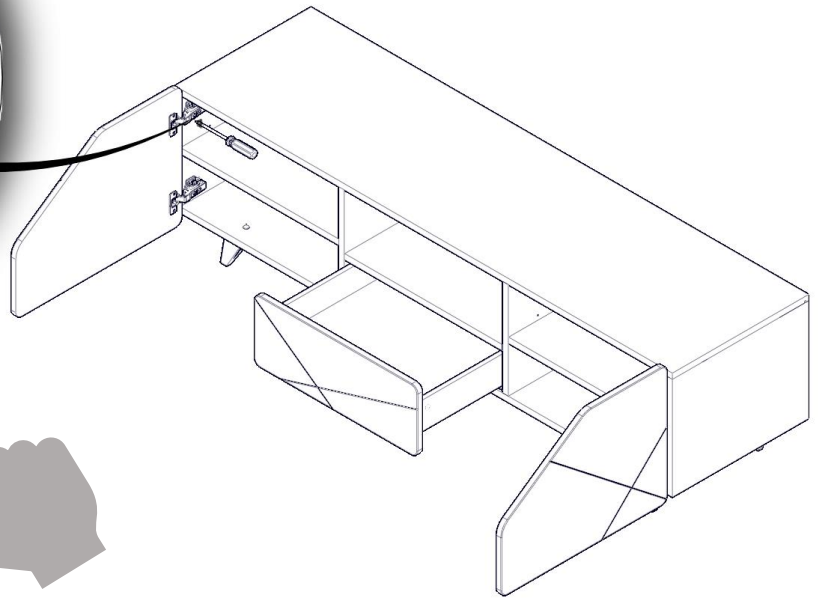
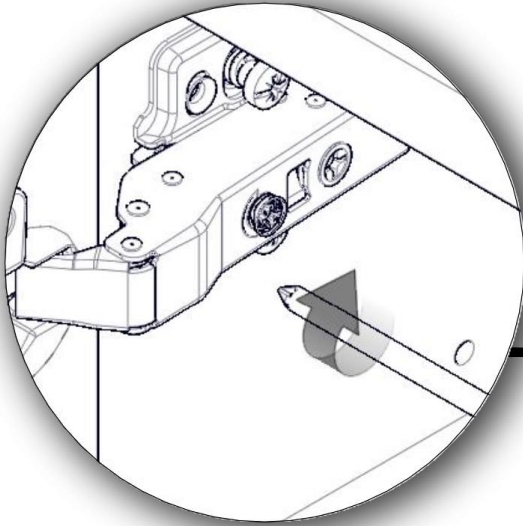

STEP 22



VELA
COLLECTION

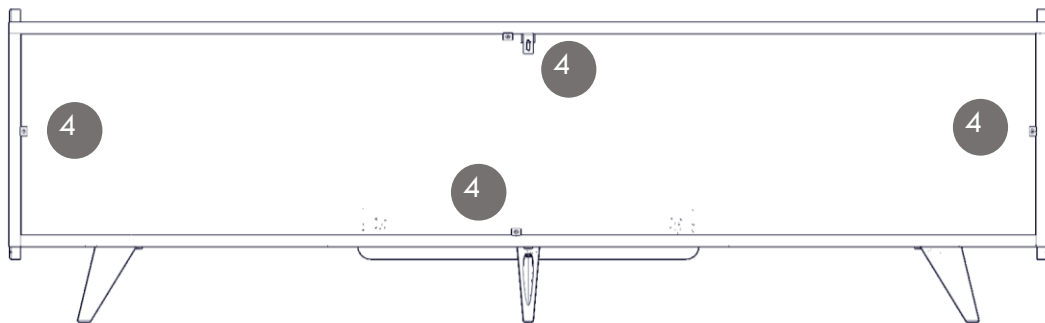
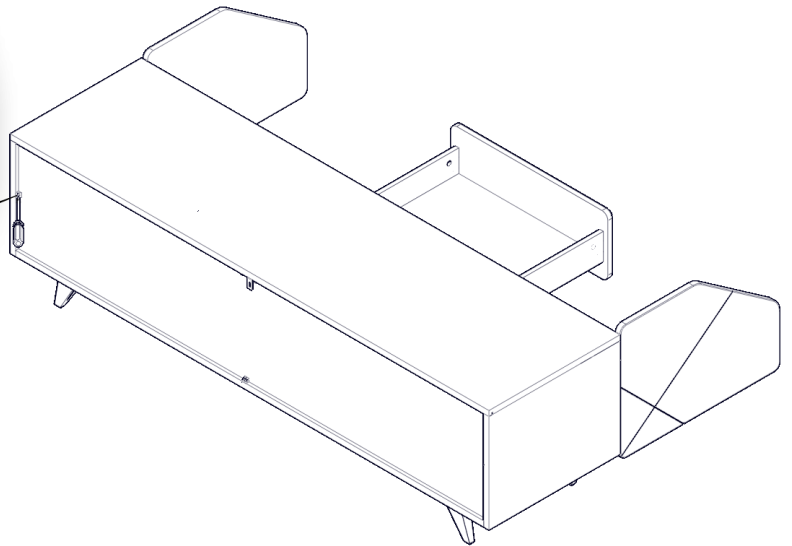
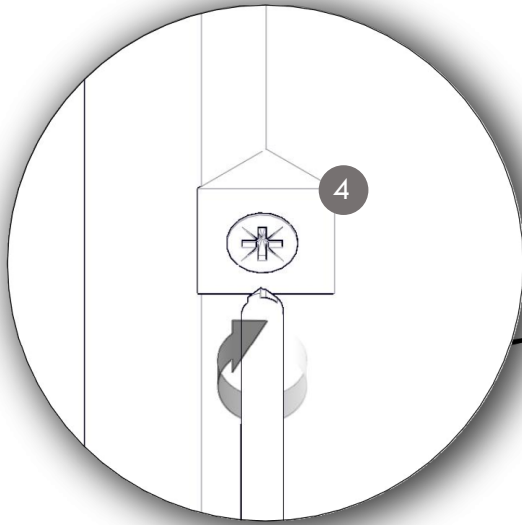
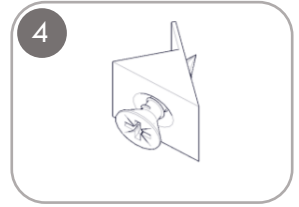

STEP 23



VELA
COLLECTION

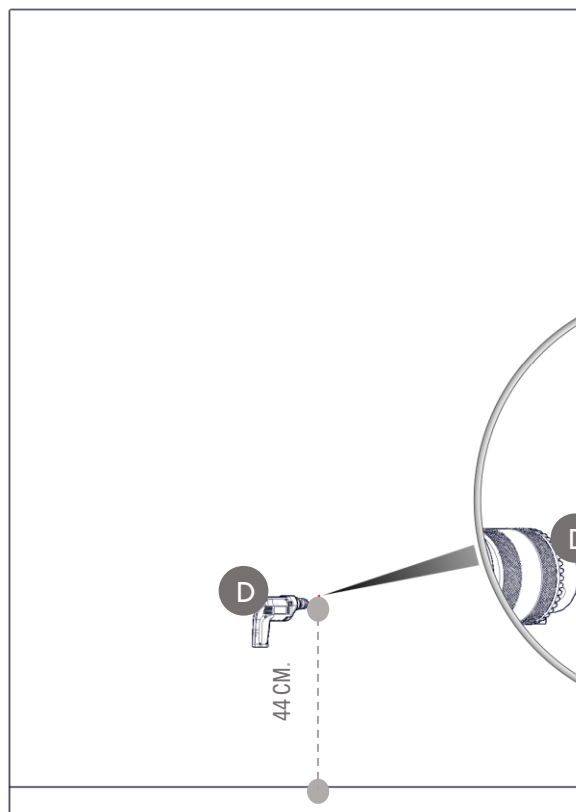
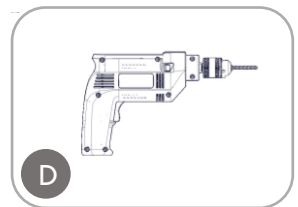
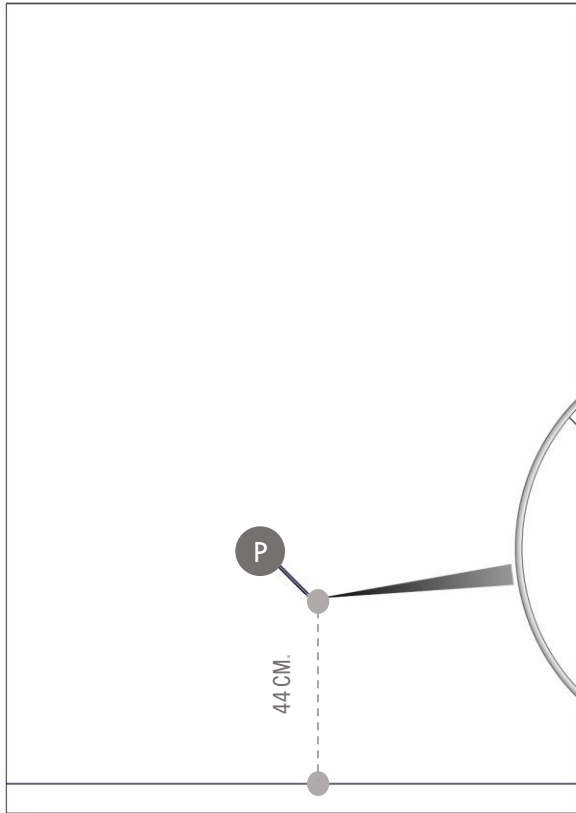
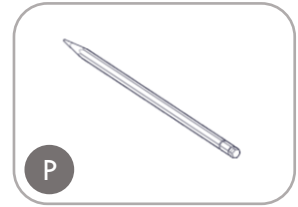

STEP 24



VELA
COLLECTION

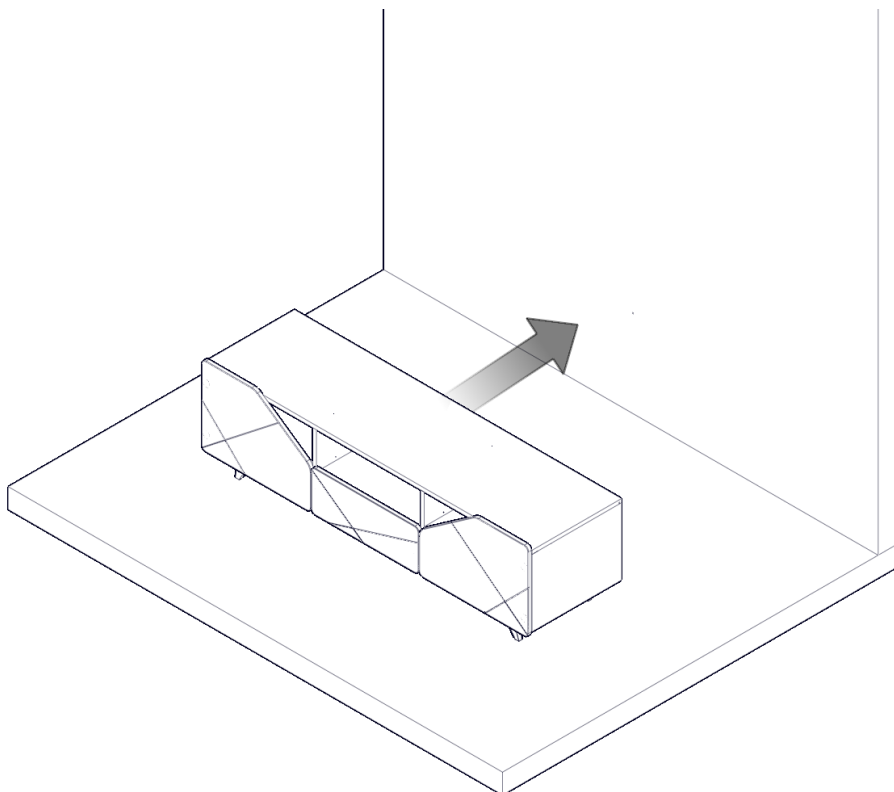
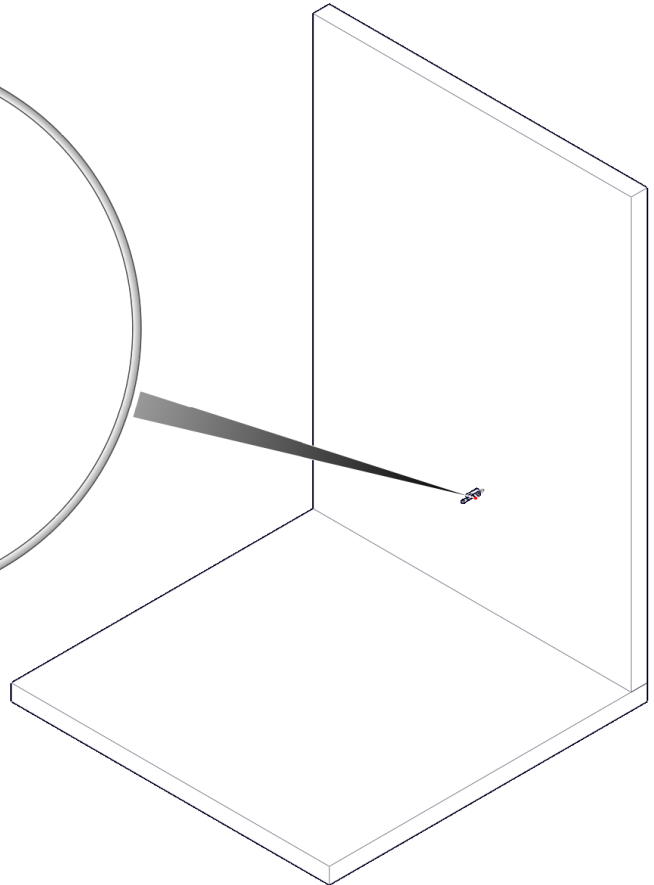
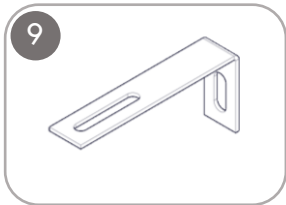
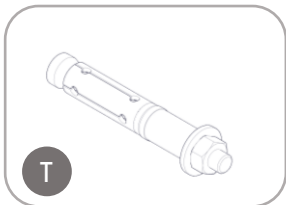
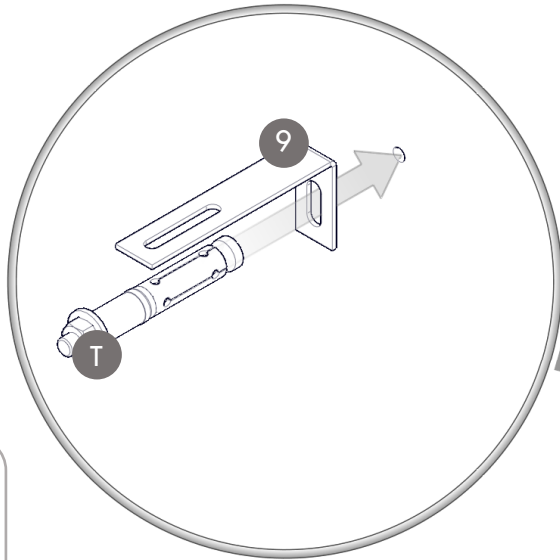

STEP 25



VELA
COLLECTION

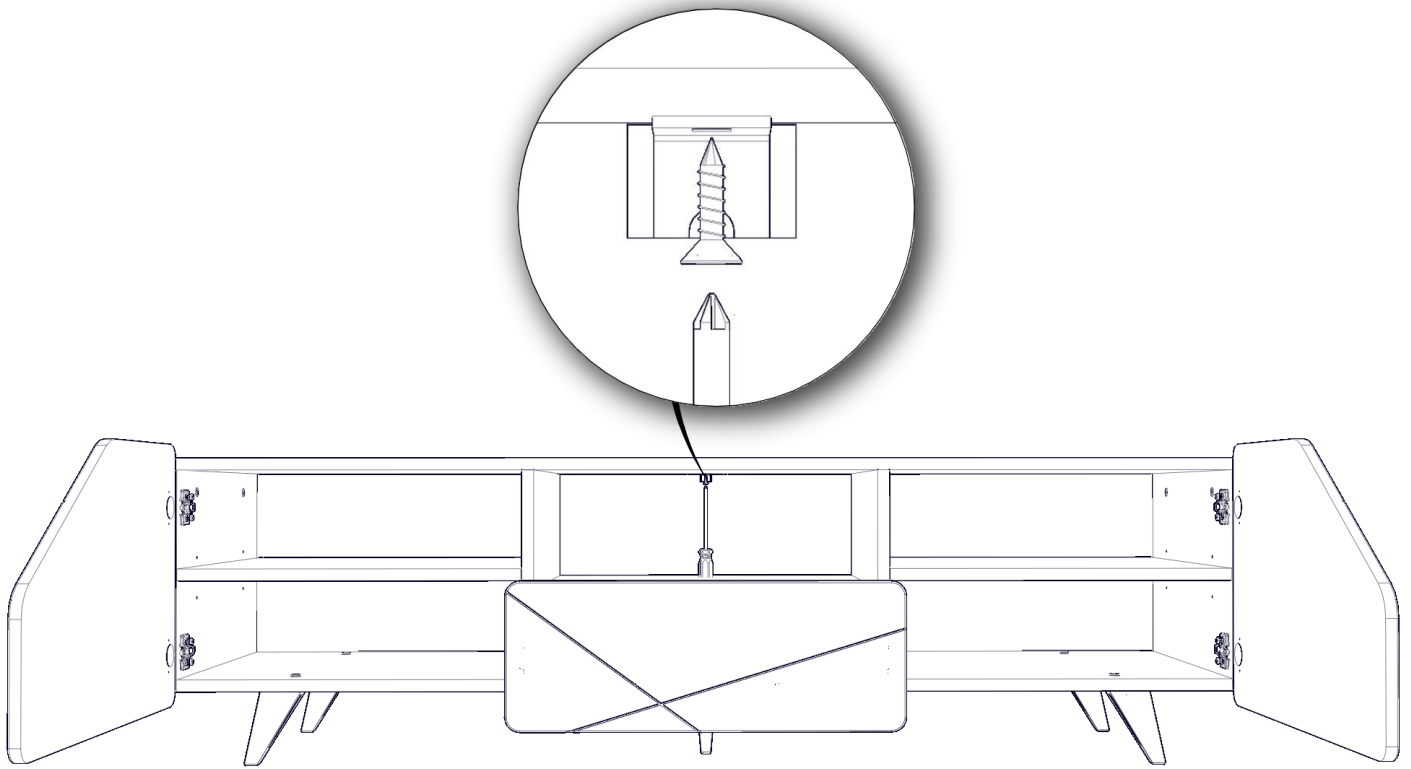
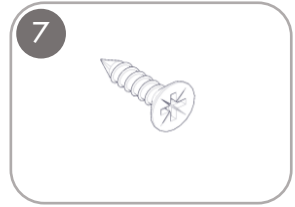

STEP 26

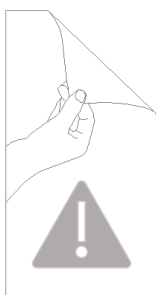
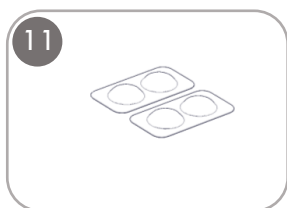

DE
DIE FOLIE AN DEN VORDERTÜREN ENTFERNEN
IT
RIMUOVERE LA PELLICOLA SULLE PORTE ANTERIORI
EN
REMOVE THE FILM ON THE FRONT DOORS
FR
RETIRER LE FILM SUR LES PORTES AVANT
NL
VERWIJDER DE FILM OP DE VOORDEUREN

