

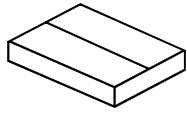

30 min

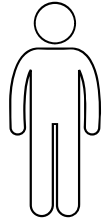

x2



x2

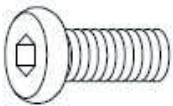

A x12

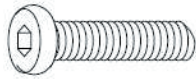

B x4



C x16

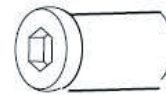

D x4



E x16



F x16



G x4



H x1

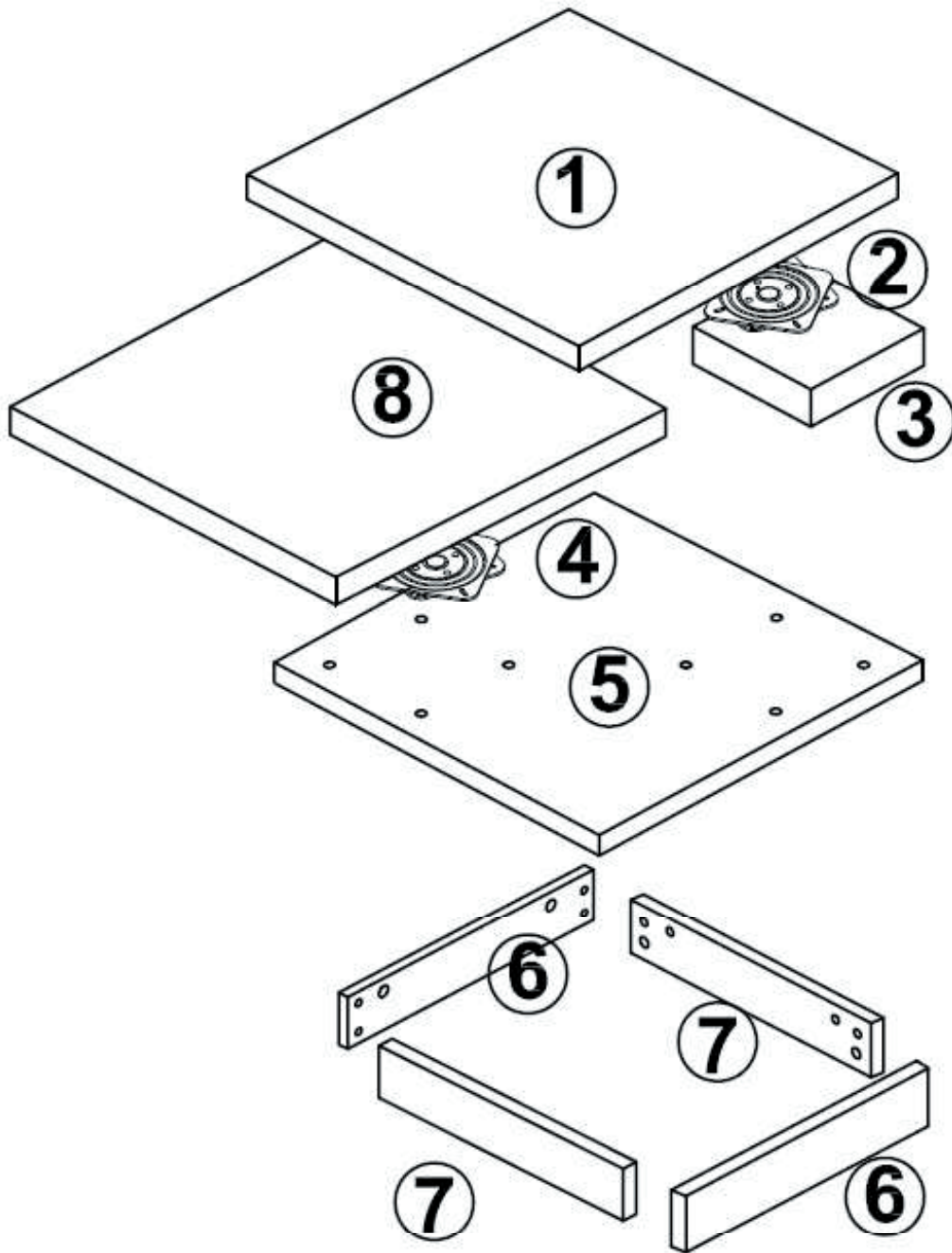

1

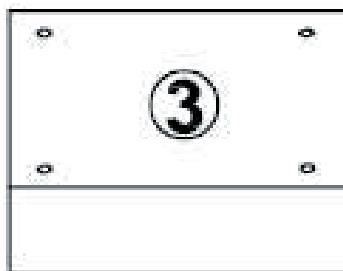
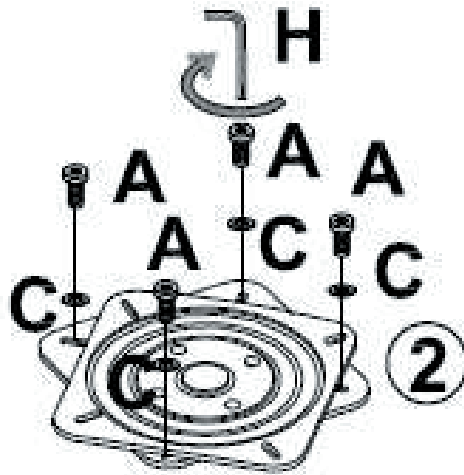

2

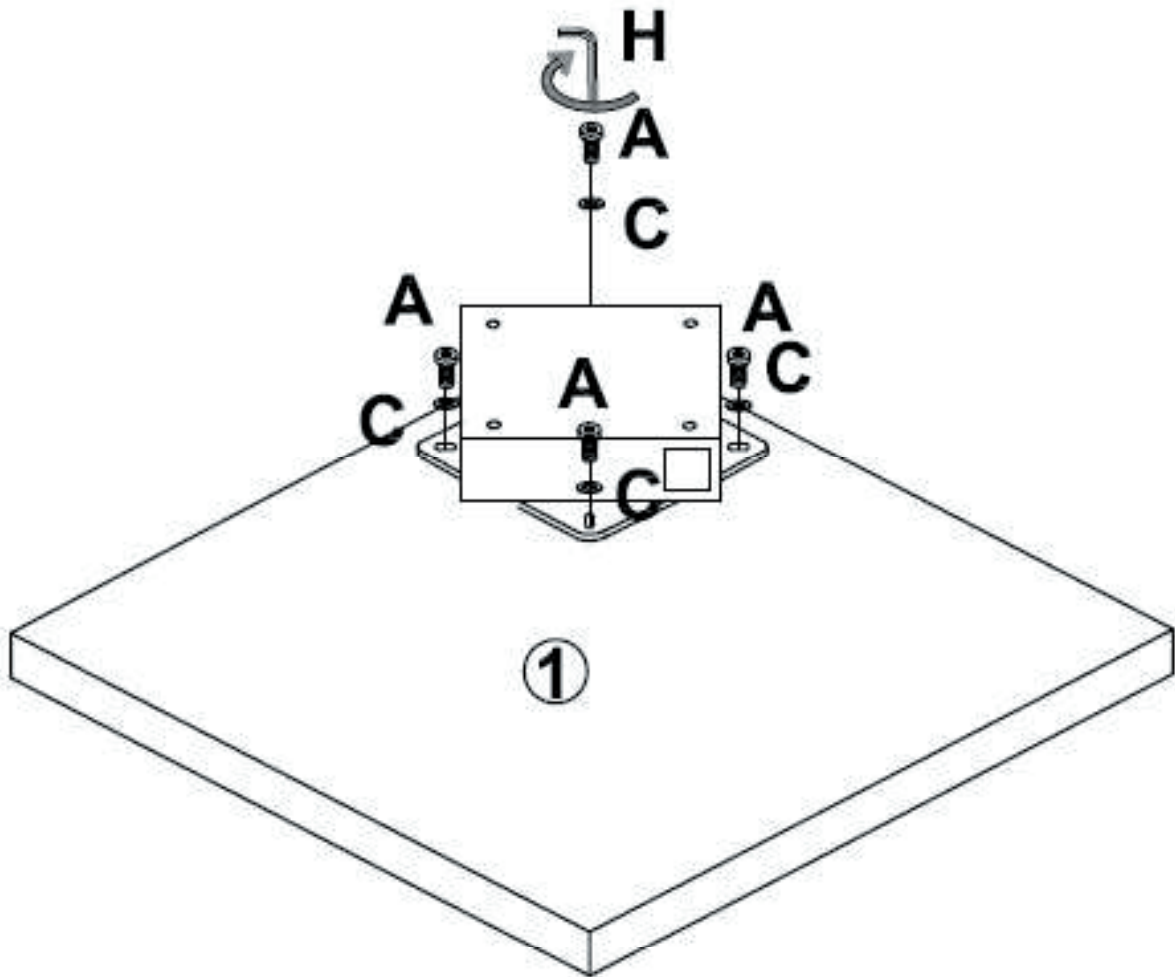

3

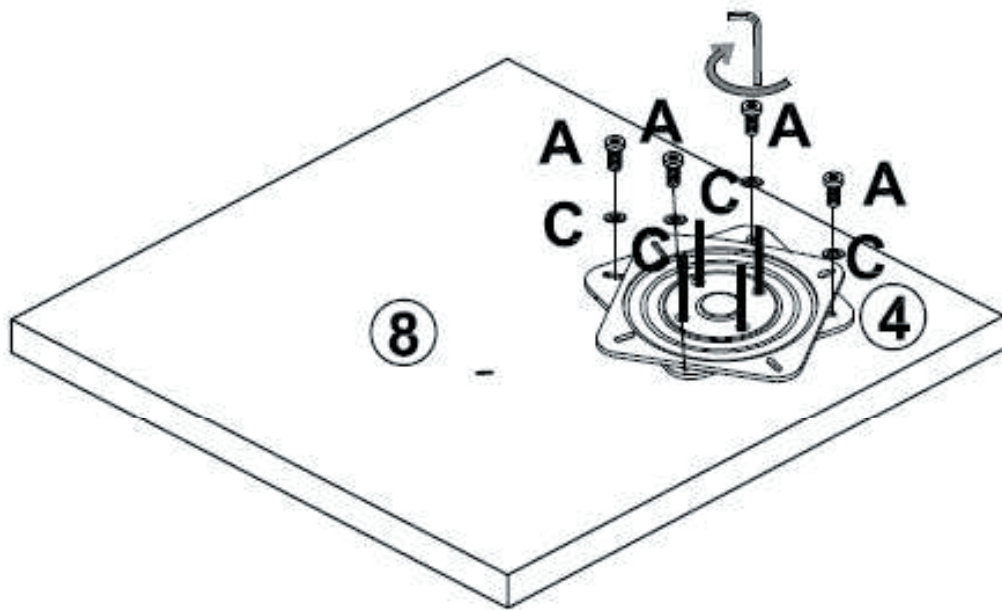

4

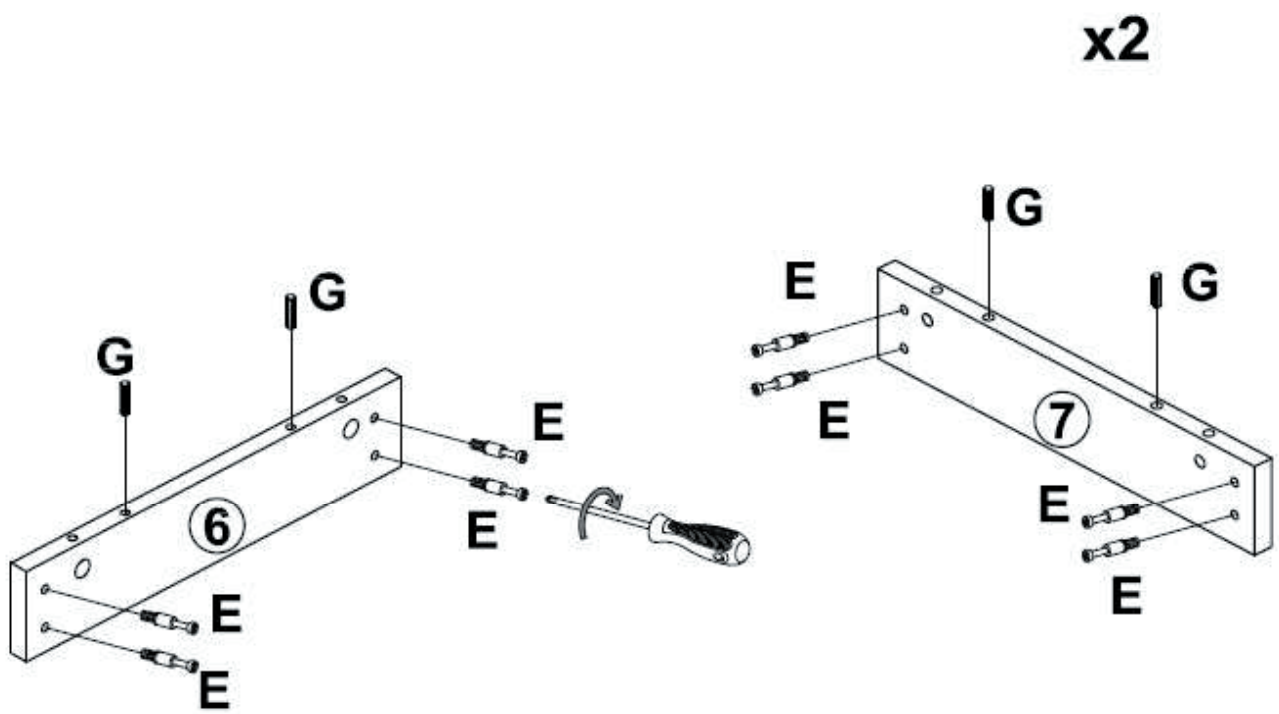



5

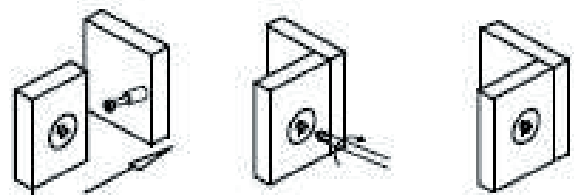
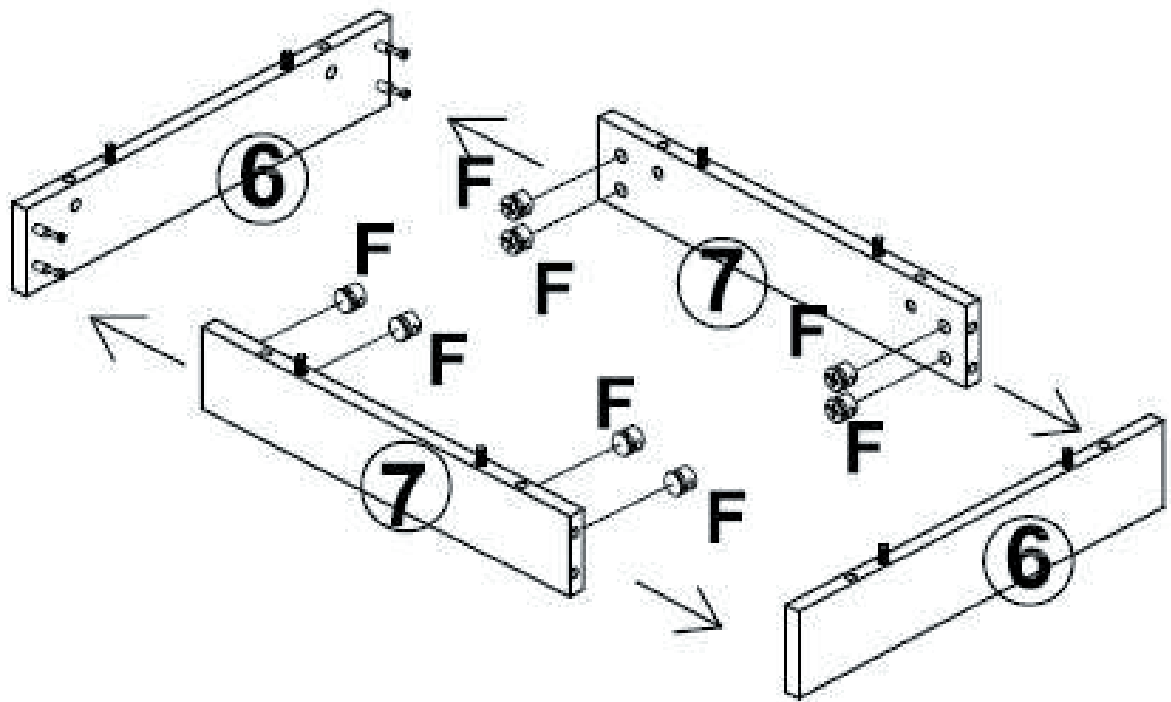

6

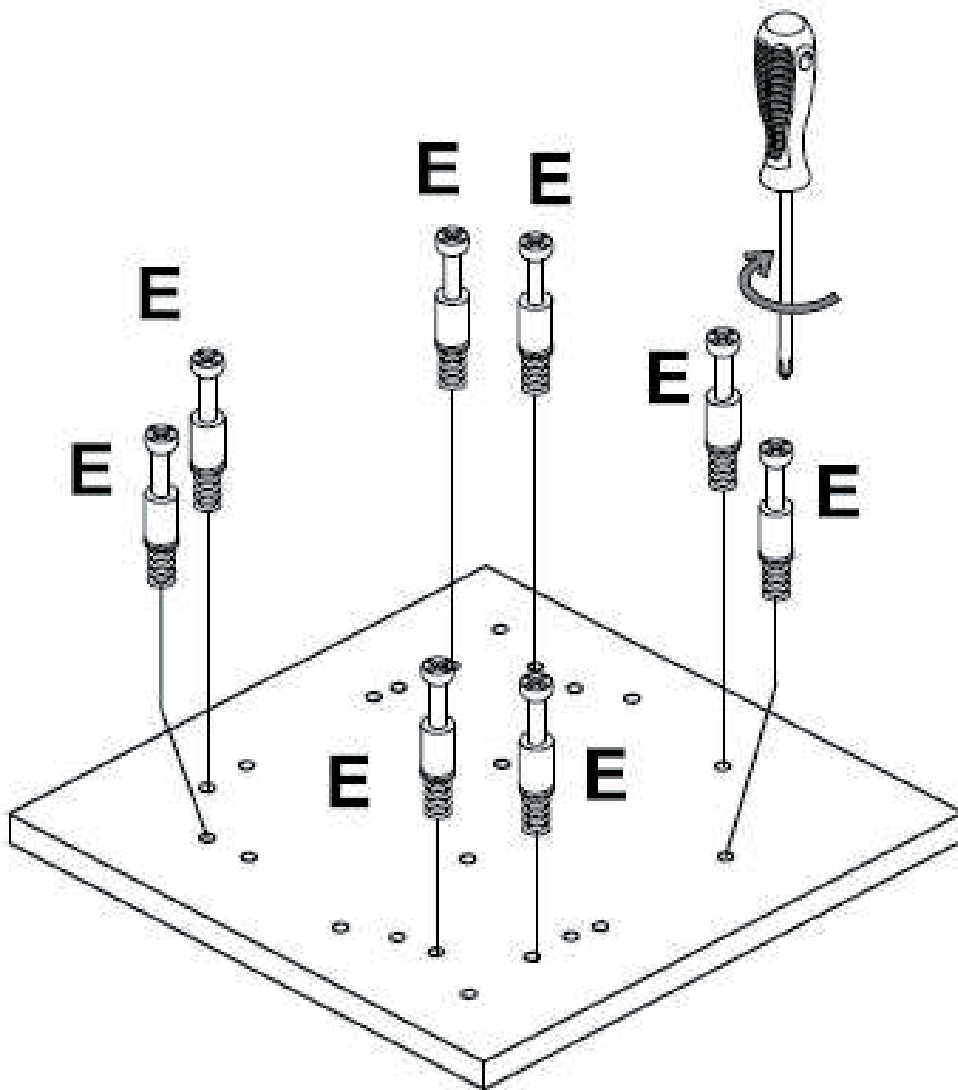

7

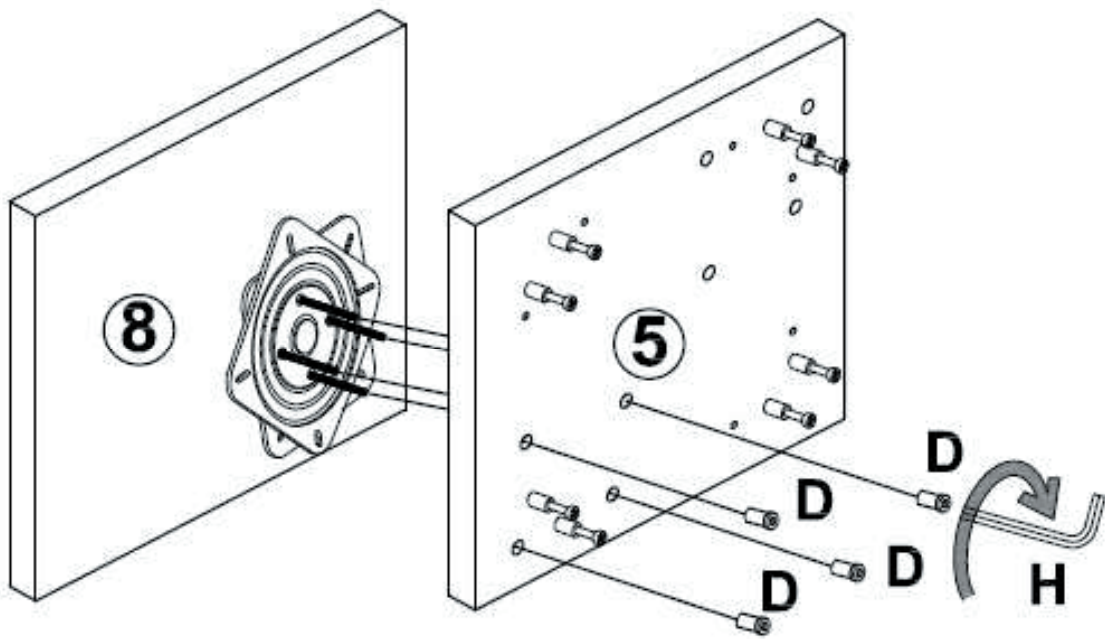

8

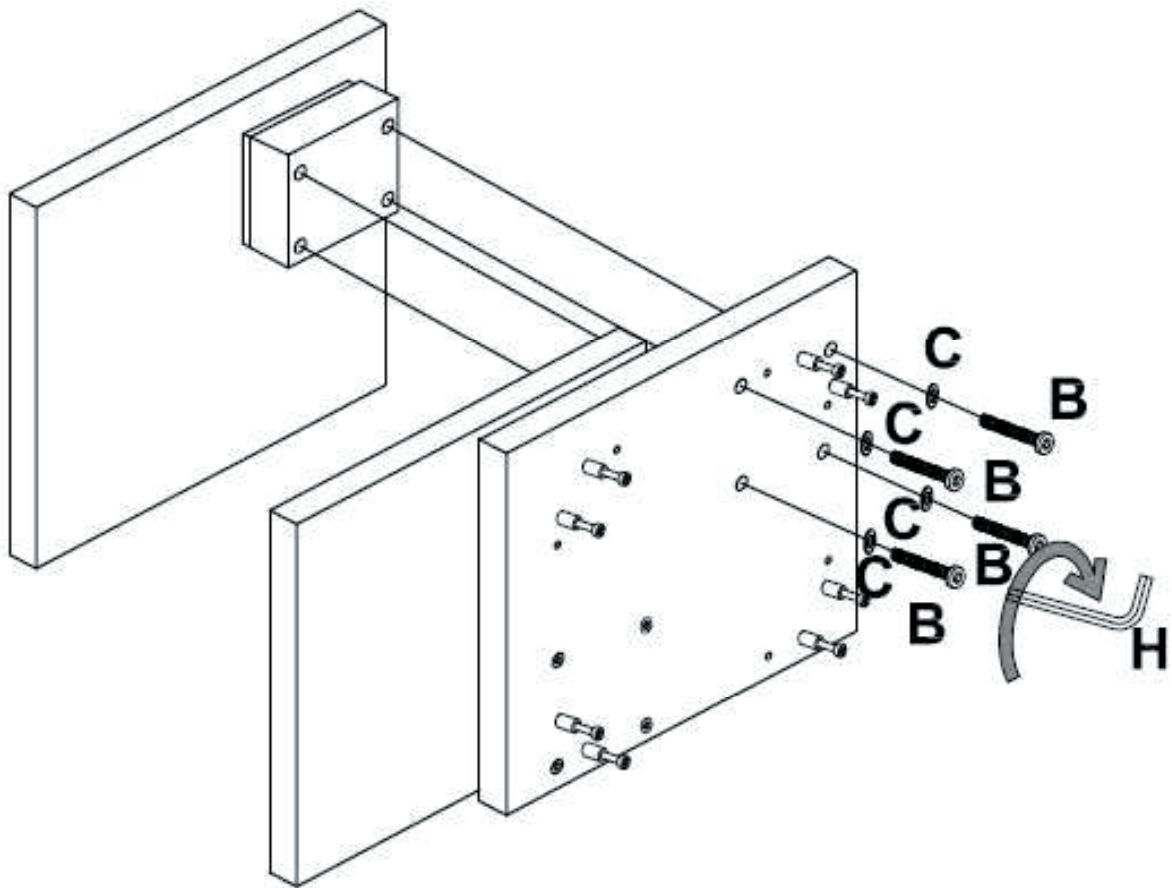

9

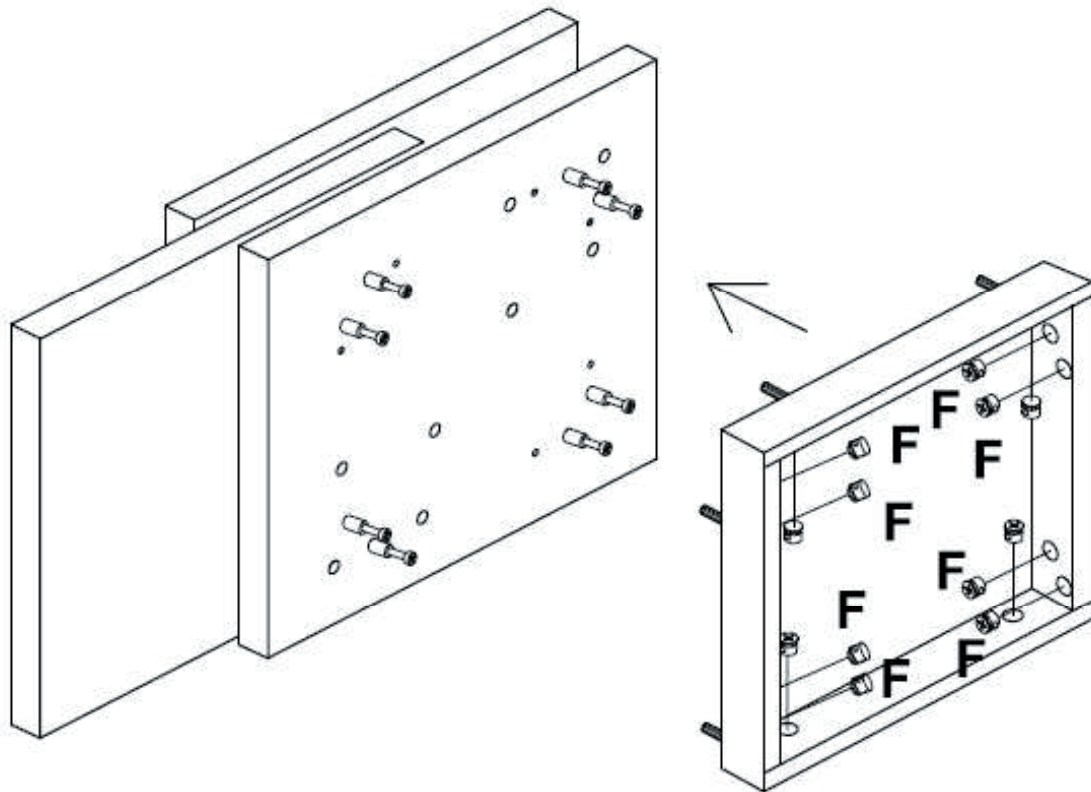

---

10

